

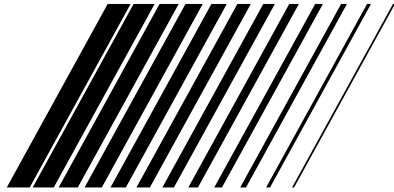

JVC



VIDEOGRABADOR VIDEO CASSETTE RECORDER

HR-J6003UM

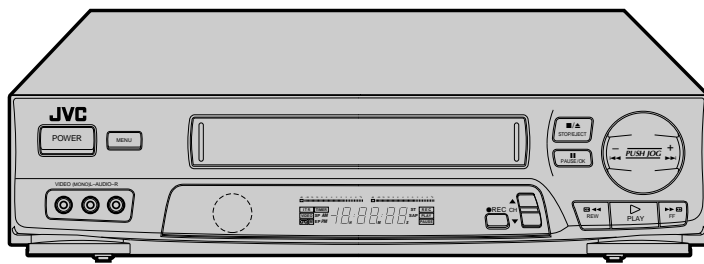
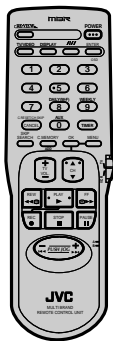

Hi-Fi **VHS**



MANUAL DE INSTRUCCIONES

INSTRUCTIONS

For Customer Use:

Enter below the Serial No. which is located on the rear of cabinet. Retain this information for future reference.

Model No. **HR-J6003UM**

Serial No. _____



2

Dear Customer,

Thank you for purchasing the JVC VHS video cassette recorder. Before use, please read the safety information and precautions contained on this page to ensure safe use of your new VCR.

CAUTIONS

WARNING: DANGEROUS VOLTAGE INSIDE
WARNING: TO PREVENT FIRE OR SHOCK HAZARD, DO NOT EXPOSE THIS UNIT TO RAIN OR MOISTURE.

The POWER button does not completely shut off mains power from the unit, but switches operating current on and off.

This unit is produced to comply with Standard IEC Publ. 65.

POWER SYSTEM:

This set operates on voltage of AC 110 – 220V~, 50/60 Hz with automatic switching.

Use the conversion plug (provided) depending on the type of your AC WALL outlet.

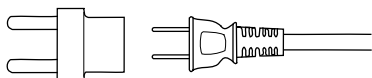

The rating plate and safety caution are on the rear of the unit.

IMPORTANT:

It may be unlawful to record or play back copyrighted material without the consent of the copyright owner.

CAUTION

- When you are not using the VCR for a long period of time, it is recommended that you disconnect the power cord from the AC outlet.
- Dangerous voltage inside. Refer internal servicing to qualified service personnel. To prevent electric shock or fire hazard, remove the power cord from the AC outlet prior to connecting or disconnecting any signal lead or aerial.
- Changes or modifications not approved by JVC could void user's authority to operate the equipment.

Failure to heed the following precautions may result in damage to the VCR, remote control or video cassette.

1. **DO NOT** place the VCR . . .
 - ... in an environment prone to extreme temperatures or humidity.
 - ... in direct sunlight.
 - ... in a dusty environment.
 - ... in an environment where strong magnetic fields are generated.
 - ... on a surface that is unstable or subject to vibration.
2. **DO NOT** block the VCR's ventilation openings.
3. **DO NOT** place heavy objects on the VCR or remote control.
4. **DO NOT** place anything which might spill on top of the VCR or remote control.
5. **AVOID** violent shocks to the VCR during transport.

**MOISTURE CONDENSATION

Moisture in the air will condense on the VCR when you move it from a cold place to a warm place, or under extremely humid conditions—just as water droplets form on the surface of a glass filled with cold liquid. Moisture condensation on the head drum will cause damage to the tape. In conditions where condensation may occur, keep the VCR's power turned on for a few hours to let the moisture dry.

**ABOUT HEAD CLEANING

Accumulation of dirt and other particles on the video heads may cause the playback picture to become blurred or interrupted. Be sure to contact your nearest JVC dealer if such troubles occur.

HOW TO USE THIS INSTRUCTION MANUAL

- All major sections and subsections are listed in the Table Of Contents on page 3. Use this when searching for information on a specific procedure or feature.
- The Index on pages 39–41 lists frequently-used terms, and the number of the first page on which they are used or explained in the manual. This section also illustrates the controls and connections on the front and rear panel, the front display panel and the remote control.
- The  mark signals a reference to another page for instructions or related information.
- Operation buttons necessary for the various procedures are clearly indicated through the use of illustrations at the beginning of each major section.

BEFORE YOU INSTALL YOUR NEW VCR . . .

. . . please read thoroughly the cautions on this page.



- Cassettes marked "VHS" (or "S-VHS") can be used with this video cassette recorder. However, only "VHS" recordings can be played back in this model.
- HQ VHS is compatible with existing VHS equipment.



CONTENTS

I NSTALLING YOUR NEW VCR **4**

Basic Connections 4

I NITIAL SETTINGS **5**

Clock 5

Preparation 5

Language Select 5

Clock Setting 6

Tuner 7

Set Receivable Channels 7

Add Or Delete A Channel 9

S IMPLE PLAYBACK AND RECORDING **10**

Simple Playback 10

Simple Recording 11

P LAYBACK AND RECORDING FEATURES **12**

Playback 12

Still Picture 12

Slow, Reverse, Reverse Slow Or Fast-Motion

Picture 12

Manual Tracking 13

Select The Soundtrack 14

Superimpose 15

Skip Search 16

Repeat Playback 16

Index Search 16

Instant ReView 17

Counter Reset 17

Counter Memory 17

Tape Position Indicator 18

Next-Function Memory 18

AV COMPU LINK Playback 18

B.E.S.T. Picture System 20

Preparation 20

Recording 21

Playback 22

Recording 23

Record One Program While

Watching Another 23

Display Elapsed Recording Time 23

Stereo And SAP (Second Audio Program) 24

To Record SAP Programs 24

T IMER RECORDING **25**

Instant Timer Recording (ITR) 25

On-Screen Timer Programming 25

Check And Cancel Programs 27

Auto SP/EP Timer 28

Auto Timer 29

E DITING **30**

Edit From A Camcorder 30

Edit To Or From Another VCR 32

Control Two JVC VCRs 32

Random Assemble Editing 33

S PECIAL FEATURES **35**

TV Multi-Brand Remote Control 35

T ROUBLESHOOTING **36**

Power 36

Tape Transport 36

Playback 36

Recording 36

Timer Recording 37

Other Problems 37

Q UESTIONS AND ANSWERS **38**

Playback 38

Recording 38

Timer Recording 38

I NDEX **39**

List Of Terms 39

Front View 40

Rear View 40

Front Display Panel 41

Remote Control 41

S PECIALIFICATIONS **42**



4

INSTALLING YOUR NEW VCR

Basic Connections

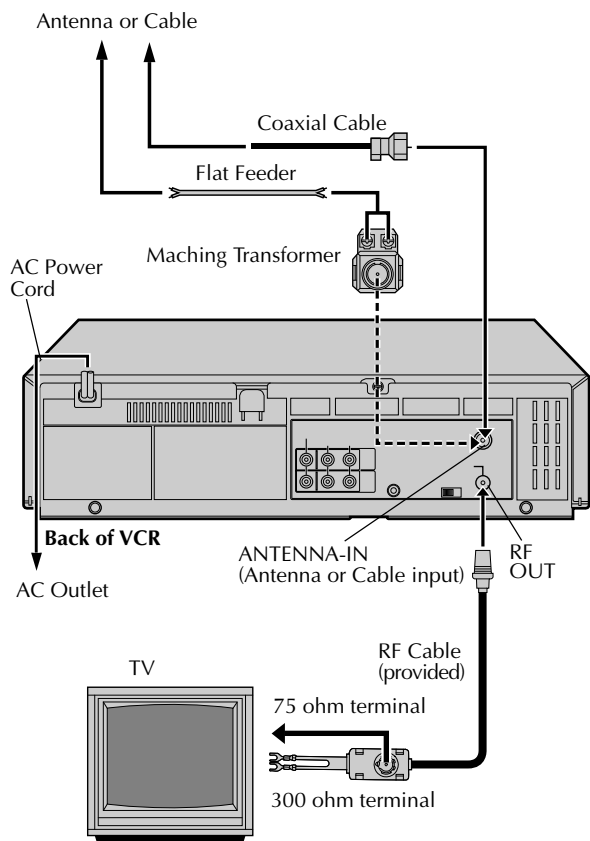

Back of VCR

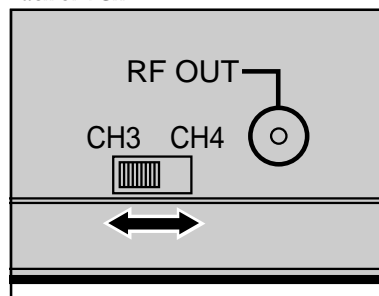

1 CHECK CONTENTS

Make sure the package contains all of the accessories listed in "SPECIFICATIONS" (☞ pg. 42).

2 SITUATE VCR

Place the VCR on a stable, horizontal surface.

3 CONNECT VCR TO TV

The connection method you use depends on the type of TV you have.

RF Connection

- To Connect To A TV With NO AV Input Terminals . . .
 - Disconnect the TV antenna cable from the TV.
 - Connect the TV antenna cable to the ANT IN jack on the rear of the VCR.
 - Connect the supplied RF cable between the RF OUT jack on the rear of the VCR and the TV's antenna terminal.

AV Connection

- To Connect To A TV With AV Input Terminals . . .
 - Connect the antenna, VCR and TV as shown in the illustration.
 - Connect an Audio/Video Cable (not supplied) between the AUDIO OUT and VIDEO OUT jacks on the rear of the VCR and the AV IN jacks on the TV.

4 CONNECT VCR TO POWER SOURCE

Connect the power plug to an AC outlet.

5 FINAL PREPARATION FOR USE

Select the VCR channel (3 or 4) by setting the switch on the rear of the VCR as shown in the illustration.

Turn on the power to the TV. You are now able to perform simple playback (☞ pg. 10) and recording (☞ pg. 11).

NOTES:

- The VCR channel is the channel on the TV which will display the audio and video signals from the VCR. The VCR's CH3-CH4 switch sets the VCR channel to CH3 or CH4.
- The CH3-CH4 switch is preset to the CH3 position. Set to CH4 if CH3 is used for broadcasting in your area.
- If your TV has no AV input terminals, set the channel on the TV to correspond to the CH3-CH4 switch on the back of the VCR.
- Even if your TV has AV input terminals, you must connect it to the VCR using an RF cable in order to record one show while watching another (☞ pg. 23).
- For full identification of the VCR's rear panel, refer to the Index (REAR VIEW ☞ pg. 40).

Clock

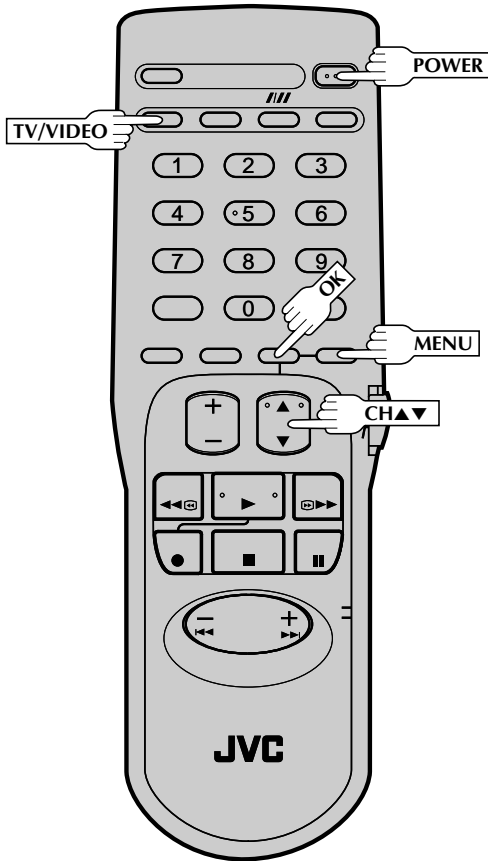
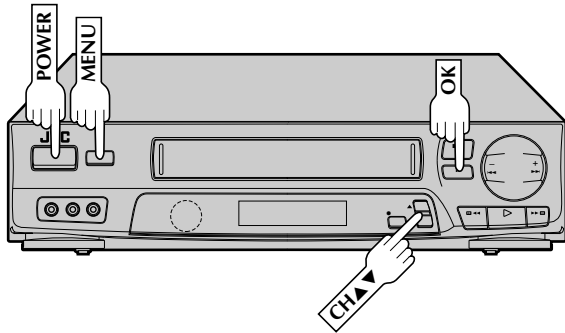

Preparation

1

TURN ON THE VCR

Press **POWER**. If watching channel 3 or 4, press **TV/VIDEO** to select the VIDEO mode. VIDEO is displayed on the front display panel.

2

ACCESS ON-SCREEN MENU

Press **MENU** to bring up the Main Menu screen.

3

ACCESS INITIAL SET SCREEN

At the Main Menu screen, place the arrow next to "AJUSTE INICIAL" by pressing **CH▲▼**, then press **OK**.



Language Select

1

ACCESS LANGUAGE SELECT SCREEN

The messages are preset to appear in Spanish. If you want to see them in English, place the arrow next to "SELECCION DE IDIOMA" by pressing **CH▲▼**, then press **OK**.



2

SELECT LANGUAGE

At the Language Select screen, place the arrow next to the desired language by pressing **CH▲▼**, then press **MENU**. The Initial Set screen reappears.





6

INITIAL SETTINGS (cont.)

Clock Setting

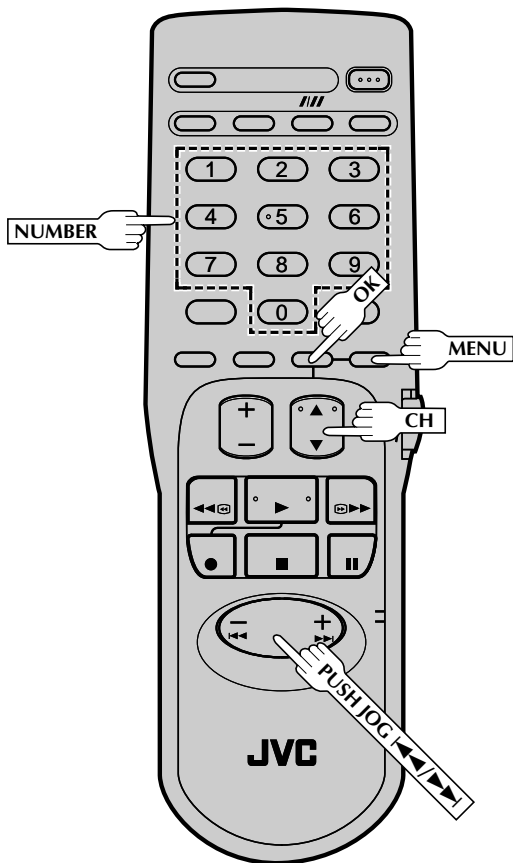
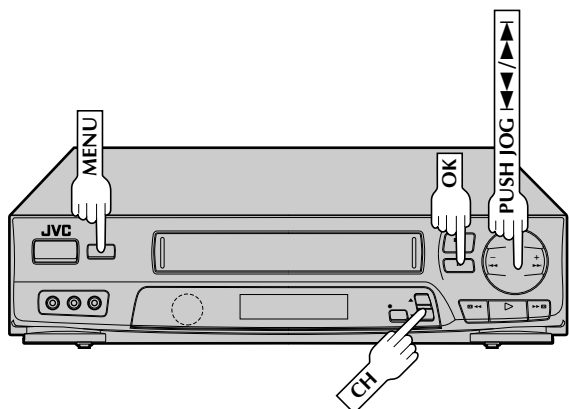

1

ACCESS CLOCK SET SCREEN

Place the arrow at the Initial Set screen next to "CLOCK SET" by pressing **CH▲▼**, then press **OK**.



2

SET DATE AND TIME

Press the appropriate **NUMBER** keys to set the date and time (if only 1 digit, press "0" first). Press **CH▲▼** to set AM/PM, then press **OK**. The next setting that can be set begins flashing. When you're finished with this set-up procedure, press **MENU** to start the clock.

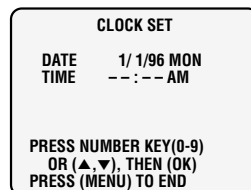

NOTE:

CH▲▼ can be used to perform all operations. (In this case, press **OK** after each setting.)

3

MAKE CORRECTIONS

To change any of the settings, press **OK** or **PUSH JOG** **◀▶▶▶** until the item you want to change blinks, then set as in step 2.

Tuner

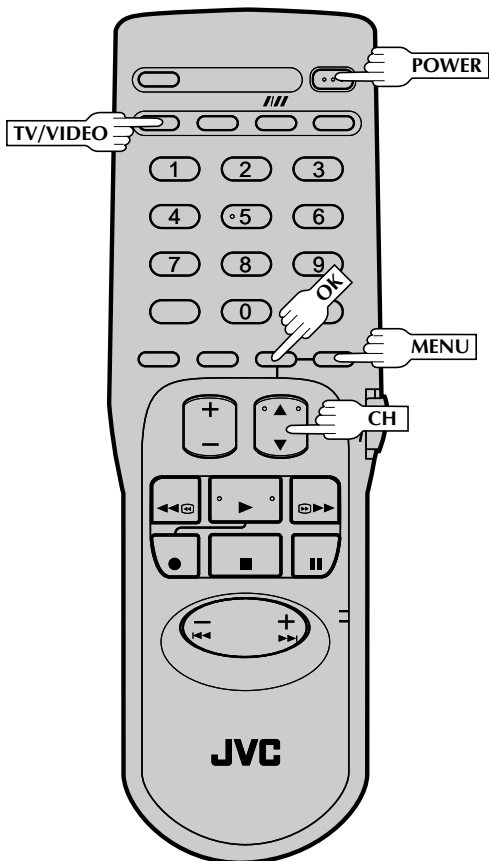
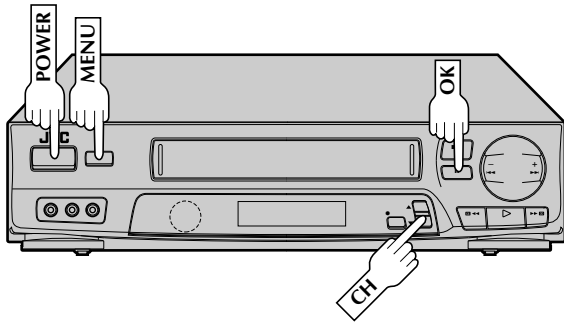

Set Receivable Channels

1

TURN ON THE VCR

Press **POWER**. If watching on channel 3 or 4, press **TV/VIDEO** to select the VIDEO mode. VIDEO is displayed on the front display panel.

2

ACCESS MAIN MENU SCREEN

Press **MENU**.

3

ACCESS TUNER SET SCREEN

Place the arrow next to "TUNER SET" by pressing **CH▲▼**, then press **OK**.

4

ACCESS BAND SCREEN

Place the arrow next to "BAND" by pressing **CH▲▼**, then press **OK**.



5

SET FREQUENCY BAND

If you receive your TV channels from an external antenna, select "TV". If you receive your TV channels from a cable TV system, select "CATV".

Place the arrow next to your choice by pressing **CH▲▼**, then press **MENU** to return to the Tuner Set screen.

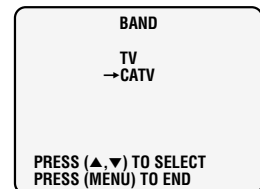

CONTINUED ON NEXT PAGE.

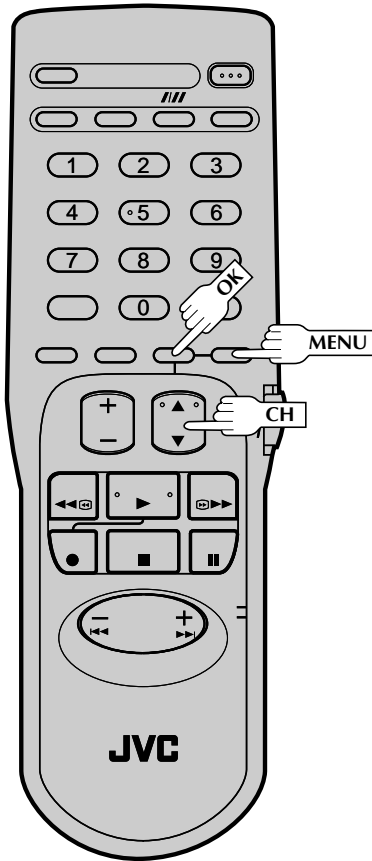
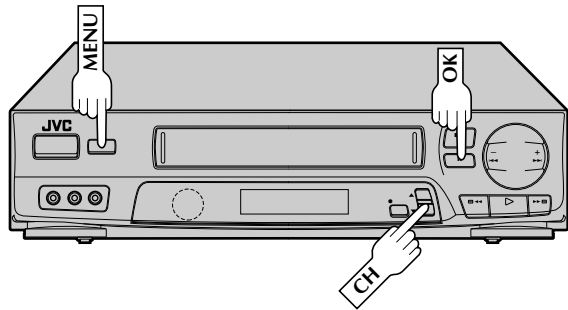

6

PERFORM AUTO CHANNEL SET

Place the arrow next to "AUTO CHANNEL SET" by pressing CH▲▼, then press OK. Receivable channels in your area are automatically assigned to the CH▲▼ buttons, and non-receivable channels are skipped.

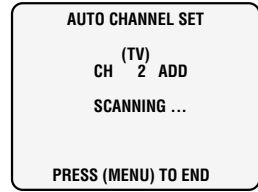

NOTES:

- At the end of Auto Channel Set, "SCAN COMPLETED" appears on screen.
- If the scan was unsuccessful, "SCAN COMPLETED-NO SIGNAL" appears on screen. Check the band setting and connections and start again.

7

RETURN TO NORMAL SCREEN

Press MENU as many times as necessary.

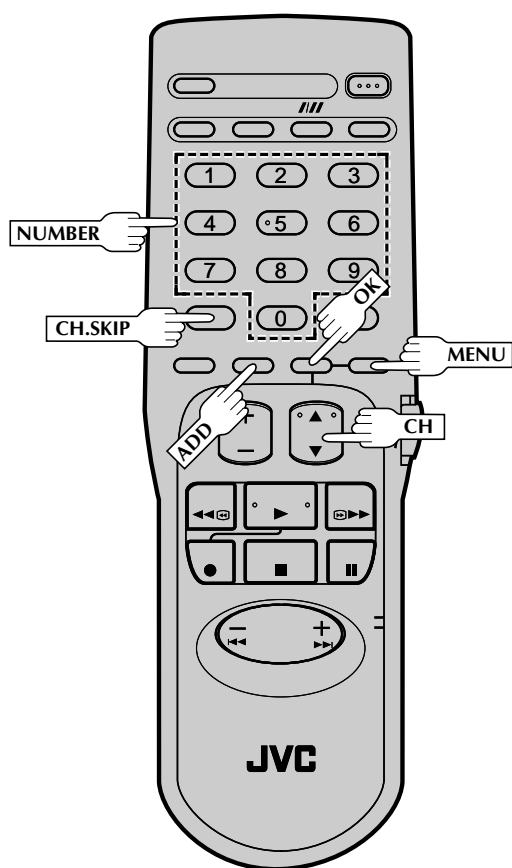
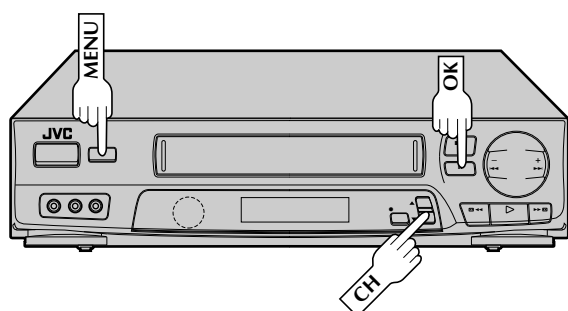

Add Or Delete A Channel

1 ACCESS TUNER SET SCREEN

Access by performing steps 2 and 3 of the Tuner procedure on page 7.

- To add a channel, go to step 2.
- To delete a channel, skip to step 4.

2 ACCESS AFC SCREEN

Place the arrow next to "AFC" by pressing **CH▲▼**, then press **OK**.

3 MAKE SELECTION

Place the arrow next to "SPCL" by pressing **CH▲▼**, then press **MENU** to return to the Tuner Set screen.

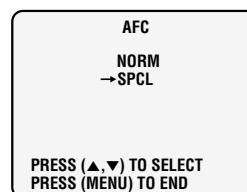

4 ACCESS MANUAL CHANNEL SET SCREEN

Place the arrow next to "MANUAL CHANNEL SET" by pressing **CH▲▼**, then press **OK**.

5 STORE DESIRED CHANNEL

Input the channel number using the **NUMBER** keys or by pressing **CH▲▼**, then press **ADD** to add or **CH.SKIP** to delete. Repeat for each channel you want to store or skip.

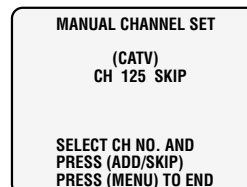

6 RETURN TO NORMAL SCREEN

Press **MENU** as many times as necessary.

Simple Playback

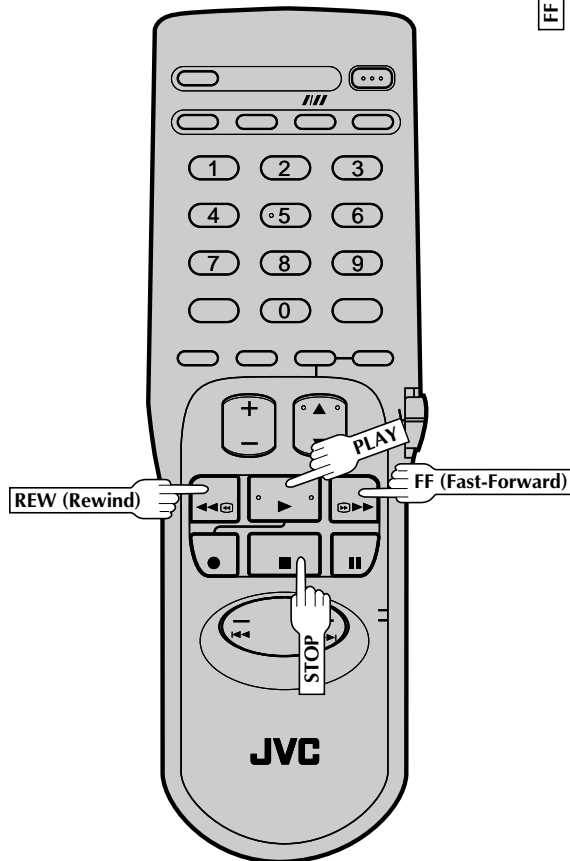
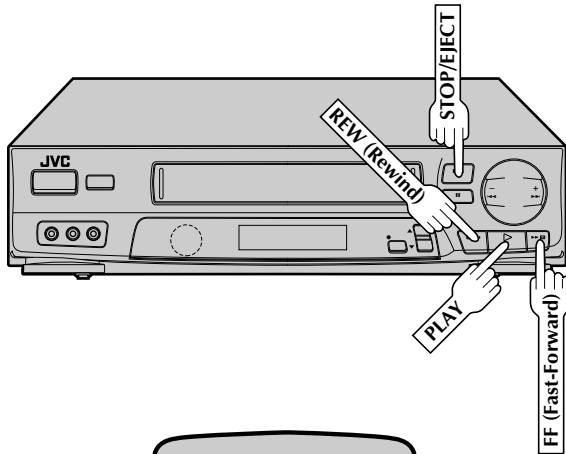

1 LOAD A CASSETTE

Make sure the window side is up, the rear label side is facing you and the arrow on the front of the cassette is pointing towards the VCR. Don't apply too much pressure when inserting.

- The VCR's power comes on automatically.
- The counter is automatically reset to "0H 00M 00S".
- If the cassette's record safety tab has been removed, playback begins automatically.

2 FIND PROGRAM START POINT

If the tape is advanced past the start point, press **REW**. To go forward, press **FF**.

3 START PLAYBACK

Press **PLAY**. "B.E.S.T. PICTURE SYSTEM" appears on screen (see pg. 22).

4 STOP PLAYBACK

Press **STOP** or **STOP/EJECT**. Then press **STOP/EJECT** to remove the cassette.

Usable cassettes

Full-Size VHS
T-30 (ST-30**)
T-60 (ST-60**)
T-90
T-120 (ST-120**)
T-160 (ST-160**)
ST-210**

Compact VHS*
TC-20 (ST-C20**)
TC-30 (ST-C30**)
TC-40 (ST-C40**)

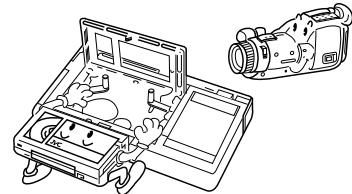

* Compact VHS camcorder recordings can be played on this video recorder. Simply place the recorded cassette into a VHS Cassette Adapter and it can be used just like any full-sized VHS cassette.

** This video recorder can record on regular VHS and Super VHS cassettes. However, it will record and play back regular VHS signals only. It is not possible to play back Super VHS recordings.



Simple Recording

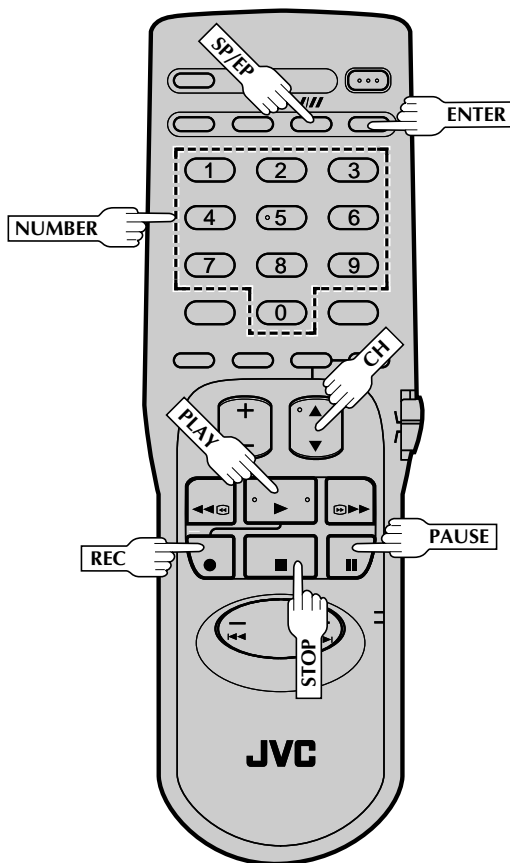
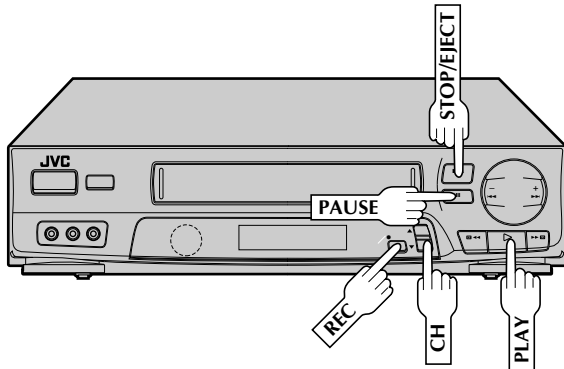

1 LOAD A CASSETTE

Make sure the record safety tab is intact. If not, cover the hole with adhesive tape before inserting the cassette.

2 SELECT RECORDING CHANNEL

Press **CH▲▼**. Or press the appropriate **NUMBER** keys, then press **ENTER**. (The channel changes after a few seconds whether you press **ENTER** or not.)

3 SET TAPE SPEED

Press **SP/EP** to set the recording speed.

4 START RECORDING

Press and hold **REC** and press **PLAY** on the remote control, or press **REC** on the VCR's front panel.

B.E.S.T. takes place at the beginning of both the first SP and the first EP recording after inserting the cassette (pg. 21).

5 PAUSE/RESUME RECORDING

Press **PAUSE**. Press **PLAY** to resume recording.

6 STOP RECORDING

Press **STOP** or **STOP/EJECT**. Then press **STOP/EJECT** to remove the cassette.

Accidental erasure prevention

- To prevent accidental recording on a recorded cassette, remove its record safety tab. To record on it later, cover the hole with adhesive tape.

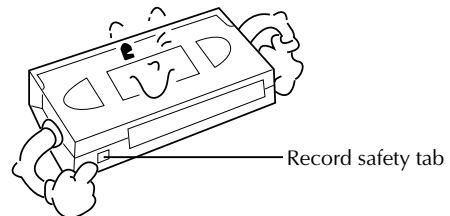

Playback

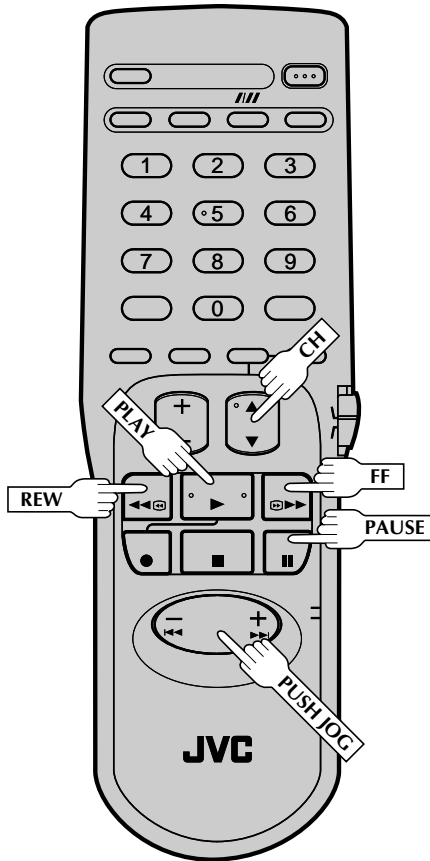
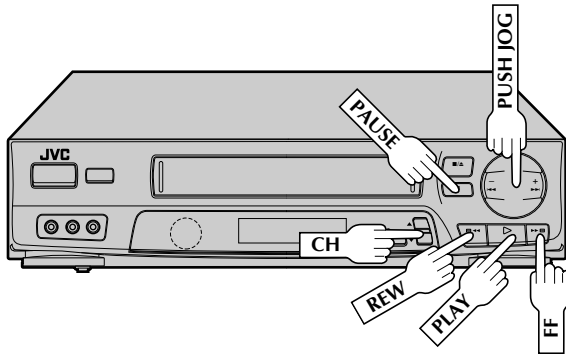

Still Picture

1 PAUSE DURING PLAYBACK

Press **PAUSE**. If there is vertical jitter, press **CH▲** or **▼** on the VCR's front panel or remote to stabilize the picture.

2 FRAME-BY-FRAME PLAYBACK

Advance the tape one frame by pressing **PAUSE** again.

- To control the direction of Frame-by-Frame playback, press **PUSH JOG ◀◀** or **▶▶** during still picture mode.

3 RESUME NORMAL PLAYBACK

Press **PLAY** during still picture mode.

Slow, Reverse, Reverse Slow Or Fast-Motion Picture

1 DURING PLAYBACK

Press **PUSH JOG ◀◀** or **▶▶**.

- To increase the speed in the forward direction, press **▶▶**.
- To decrease the speed in the forward direction, press **◀◀**.
- To play in reverse slow motion, and in reverse play mode, continue to press **◀◀** after selecting all the forward slow motion modes.

Press **FF** for forward fast motion, or **REW** for reverse fast motion.

2 RESUME NORMAL PLAYBACK

Press **PLAY**.

NOTES:

- Press and hold **FF** or **REW** for more than 2 seconds for short fast-motion searches. When the button is released, normal playback resumes.
- If noise bars appear during playback or slow motion, correct using manual tracking. (☞ pg. 13).

Manual Tracking

Once playback begins, the VCR's automatic tracking function is engaged. If noise appears in the picture, you can override this and make the adjustment manually.

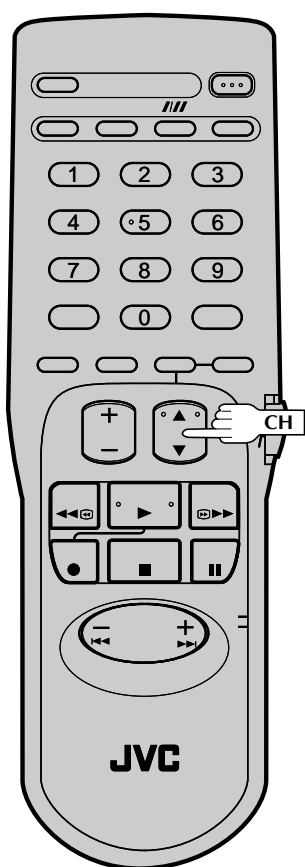
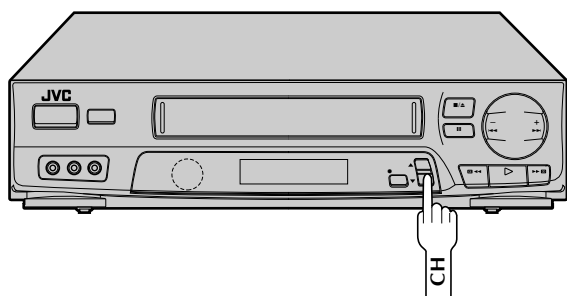

1 ENGAGE MANUAL TRACKING MODE

During playback, press the **CH▲▼** buttons on the VCR's front panel simultaneously to cancel the automatic tracking mode and enable manual tracking adjust.

2 ADJUST MANUAL TRACKING

Press **CH▲▼** on the VCR's front panel or remote. Press lightly for fine adjust, or press and hold for coarse adjust. Watch the screen and continue adjusting until optimum picture and sound quality are achieved.

3 RE-ENGAGE AUTOMATIC TRACKING

Press the **CH▲▼** buttons on the VCR's front panel simultaneously.

- When automatic tracking is re-engaged, video calibration is automatically activated.

NOTE:

During slow-motion playback, simply press **CH▲** or **▼** on the VCR's front panel or remote to adjust tracking.

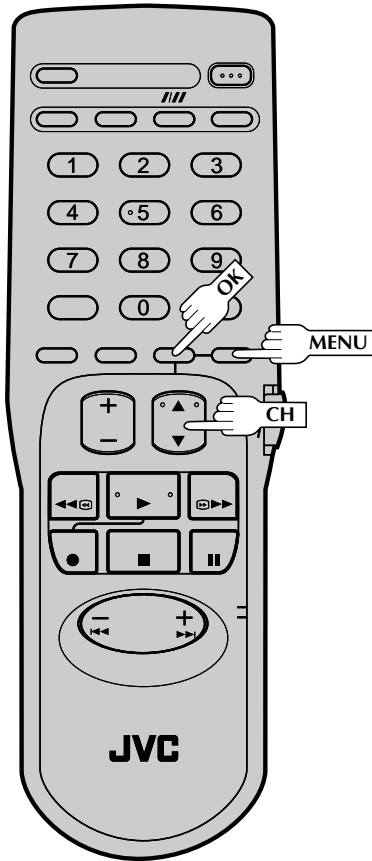
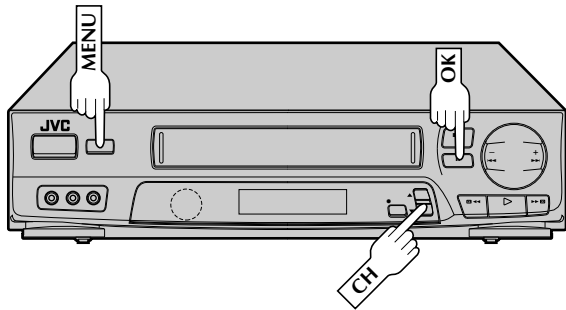

Select The Soundtrack

Your VCR can record two soundtracks simultaneously (Normal and Hi-Fi) and play back the selected one, or both together. Or, when viewing a pre-recorded tape that contains both a main and a sub audio track, you can choose to listen to either one by selecting either "L" or "R" in step 4.

1 ACCESS MAIN MENU SCREEN

Press **MENU** during playback or when VCR is in stop mode.

2 ACCESS FUNCTION SET SCREEN

Place the arrow next to "FUNCTION SET" by pressing **CH▲▼**, then press **OK**.

3 ACCESS AUDIO MONITOR SCREEN

Place the arrow next to "AUDIO MONITOR" by pressing **CH▲▼**, then press **OK**.

```

FUNCTION
AUTO TIMER
SUPERIMPOSE
2ND AUDIO
→AUDIO MONITOR
AUX INPUT
AUTO SP/EP TIMER
SPECIAL FUNCTION
PRESS (▲, ▼), THEN (OK)
PRESS (MENU) TO END
  
```

4 SELECT MODE

You have five choices:

- a- Hi-Fi
- b- Left
- c- Right
- d- Normal
- e- Mix

```

AUDIO MONITOR
→HI-FI
L
R
NORM
MIX
PRESS (▲, ▼) TO SELECT
PRESS (MENU) TO END
  
```

Place the arrow next to your choice by pressing **CH▲▼**.

- The indicator on the front display panel representing the mode you selected lights up (Hi-Fi: L+R; L: L; R:R; NORM: No display; MIX: L+R).

5 RETURN TO NORMAL SCREEN

Press **MENU** as many times as necessary.

NOTE:

If the tape being played back has no Hi-Fi soundtrack, the Normal soundtrack will be heard no matter what choice you make at the Audio Monitor screen.

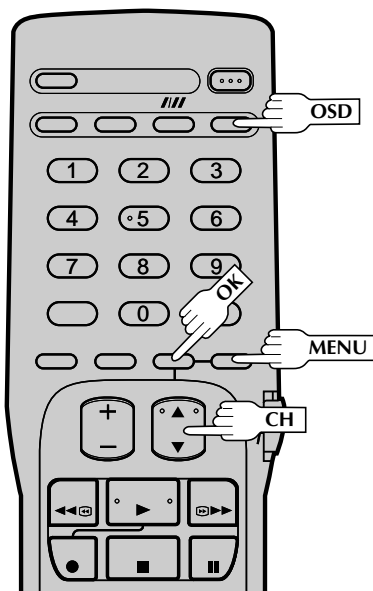
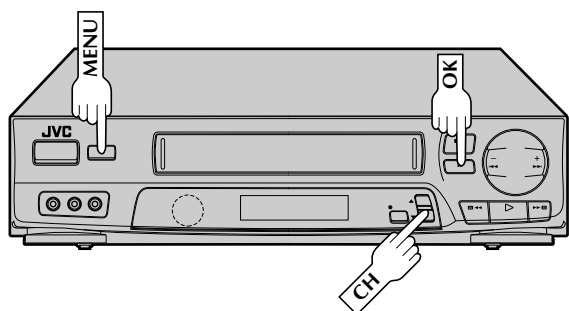

To recall an indication

- 1 Press **OSD**.
 - All indications corresponding to the current status are displayed for 5 seconds, leaving the counter information, and RECORD/PAUSE if in the Record Pause mode, on the screen. (No indication during still and search.)
- 2 Press **OSD** again to clear the display.

Superimpose

This function, switchable between ON and OFF, determines whether or not operational indicators will appear on screen.

- 1 **ACCESS MAIN MENU SCREEN**
Press **MENU**.
- 2 **ACCESS FUNCTION SET SCREEN**
Place the arrow next to "FUNCTION SET" by pressing **CH▲▼**, then press **OK**.
- 3 **ACCESS SUPERIMPOSE SCREEN**
Place the arrow next to "SUPERIMPOSE" by pressing **CH▲▼**, then press **OK**.

FUNCTION

AUTO TIMER
→SUPERIMPOSE
2ND AUDIO
AUDIO MONITOR
AUX INPUT
AUTO SP/EP TIMER
SPECIAL FUNCTION
PRESS (▲,▼), THEN (OK)
PRESS (MENU) TO END
- 4 **SELECT MODE**
Place the arrow next to "ON" or "OFF" by pressing **CH▲▼**.

SUPERIMPOSE

→ON
OFF

PRESS (▲,▼) TO SELECT
PRESS (MENU) TO END
- 5 **RETURN TO NORMAL SCREEN**
Press **MENU** as many times as necessary.

NOTE:

If you engage the Record Pause mode, RECORD/PAUSE is displayed whether "SUPERIMPOSE" is set to "ON" or "OFF".

The superimposed indication on the TV screen tells you what the VCR is doing.

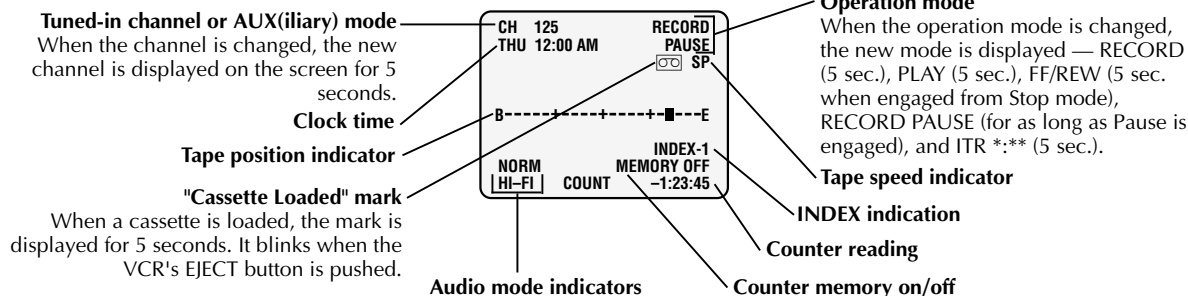

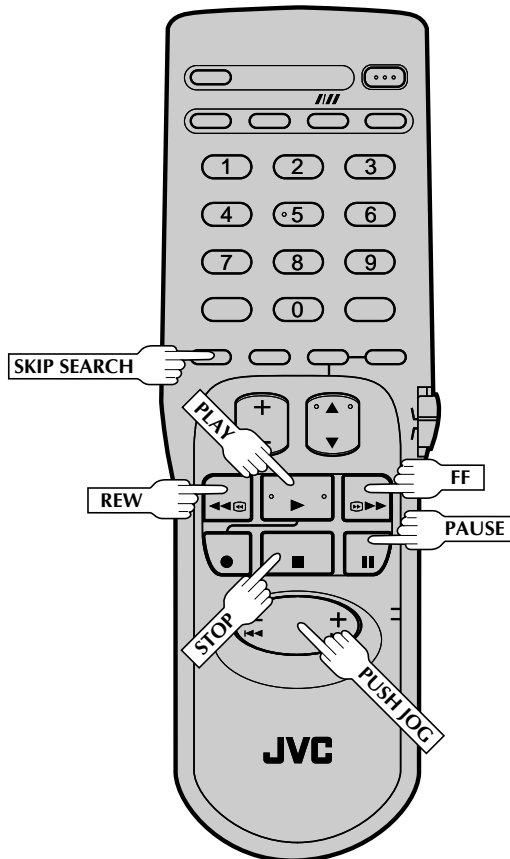
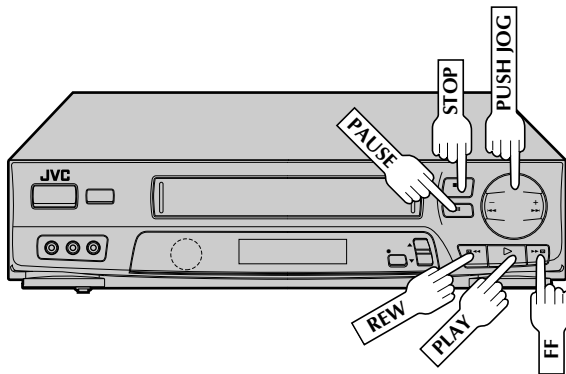

Skip Search

1

SKIP OVER UNWANTED SECTIONS

Press **SKIP SEARCH** 1 to 4 times during playback. Each press initiates a 30-second period of fast-motion playback. Normal playback resumes automatically.

NOTE:

To return to normal playback during a Skip Search, press **PLAY**.

Repeat Playback

1

START REPEAT

Press and hold **PLAY** (until "PLAY" blinks on the front display panel) during playback, then release.

- The entire tape is played back 20 times.

2

STOP REPEAT

To stop, press **STOP** at any time.

NOTE:

Pressing **PLAY**, **REW**, **FF**, **PAUSE** or **PUSH JOG** ◀◀ or ▶▶ also stops Repeat Playback.

Index Search

This function seeks out index codes that are placed on the tape at recording start.

1

START SEARCH

While the tape is stopped, press **PUSH JOG** ◀◀ or ▶▶.

2

ACCESS DISTANT CODE

To access a recording 2–9 index codes away, press **PUSH JOG** ◀◀ or ▶▶ repeatedly until the correct number is displayed on screen (only if **SUPERIMPOSE** is set to **ON** (pg. 15)). Playback begins automatically when desired recording is located.

- To find the very beginning of the desired program, press **REW** or **FF** and search visually for the start point.

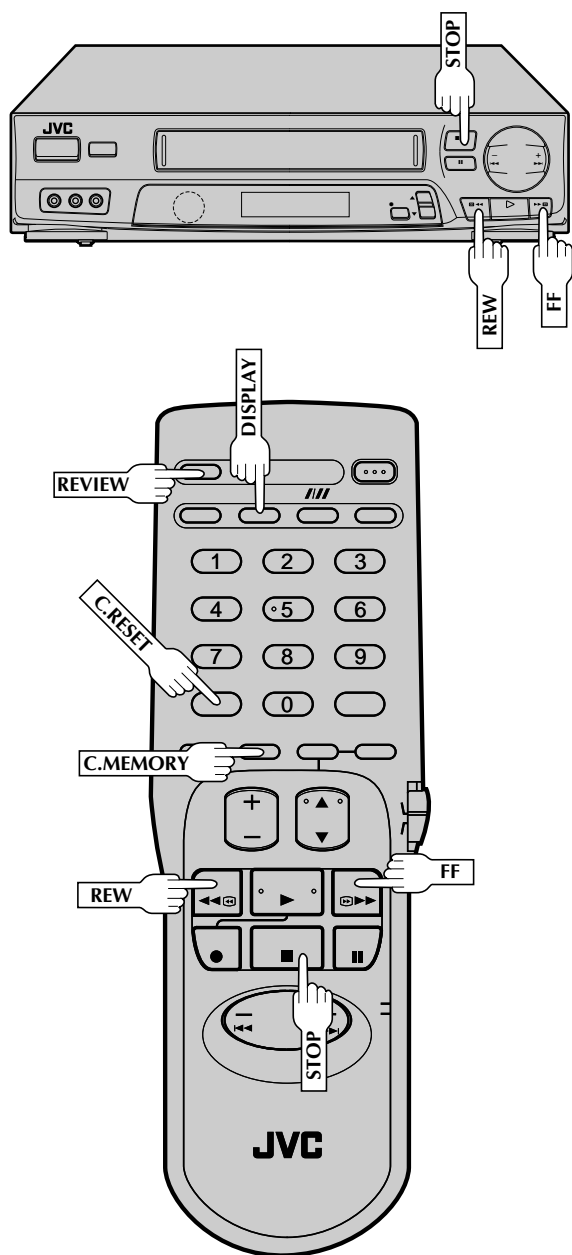

Instant ReView

At the press of a button, you can power up your VCR, rewind the tape and begin viewing the most recent timer-recorded program.

1 ACTIVATE INSTANT REVIEW

After ensuring that the VCR is off and the Timer mode is disengaged, press **REVIEW**.

- The power comes on and the VCR searches for the index code indicating the start of the last timer-recorded program, then begins playback automatically.
- You can access a program 2–9 index codes away from the current position on the tape. If, for example, you have 5 programs recorded and you want to watch the third one, press **REVIEW** three times.
- To find the very beginning of the desired program, press **REW** or **FF** and search visually for the program's start point.

Counter Reset

1 RESET COUNTER TO ZERO

Press **C.RESET**.

NOTE:

By pressing the **DISPLAY** button, you can change the display to show the counter reading, channel number or clock time. (Channel number is not displayed during playback.)

Counter Memory

When activated, this feature returns the tape to counter position "zero".

1 ACTIVATE COUNTER MEMORY

Press **C.RESET** during playback at a point you want to have quick access to later. The counter reads "0H 00M 00S".

Then press **C.MEMORY**. The Counter Memory indicator in the front display panel lights.

2 RETURN TO COUNTER POSITION ZERO

Press **STOP** (during playback), then press **REW**. The tape rewinds and stops at approximately "0H 00M 00S" automatically.

- To cancel Counter Memory, press **C.MEMORY**.

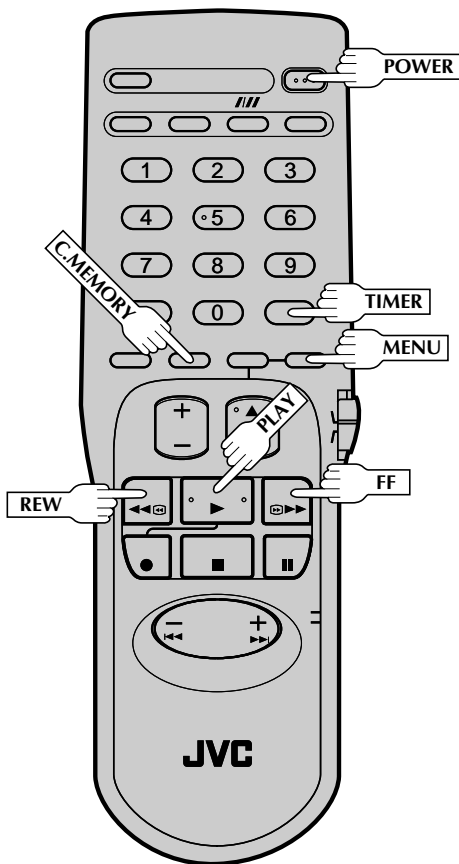
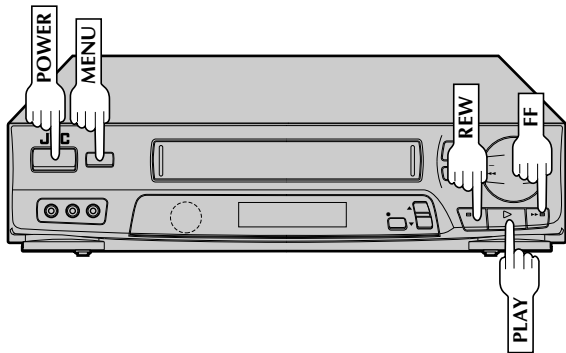

Tape Position Indicator

The Tape position indicator appears on screen when, from the stop mode, you press **FF**, **REW** or perform an Index Search or Instant ReView. The position of "■" in relation to "B" (Beginning) or "E" (End) shows you where you are on the tape.

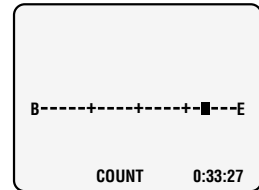

NOTE:

SUPERIMPOSE must be set to ON, or the indicator will not appear (☞ pg. 15).

Next-Function Memory

The Next Function Memory "tells" the VCR what to do after rewinding.

- * Before continuing, ensure that the VCR is in stop mode.
- a- For Automatic Start Of Playback After Tape Rewind . . .
... press **REW**, then press **PLAY** within 2 seconds.
- b- For Automatic Power Off After Tape Rewind . . .
... press **REW**, then press **POWER** within 2 seconds.
- c- For Automatic Timer Standby After Tape Rewind . . .
... press **REW**, then press **TIMER** within 2 seconds.

NOTE:

*If you want the "next function" to automatically start when the counter reads "0H 00M 00S" (instead of at the beginning of the tape), press **C. MEMORY** so that the counter memory indicator appears on the front display panel before pressing **REW** or **FF**.*

AV COMPU LINK Playback

Your VCR is compatible with JVC's AV COMPU LINK components, including amplifiers (or receivers) and televisions. AV COMPU LINK provides one touch control of the audio and video components that are linked via their AV COMPU LINK connectors.

For example: simply load a cassette in the VCR and press **PLAY** and the AV COMPU LINK components automatically power on, the TV's VIDEO mode is selected and the VCR goes into play mode. (**PLAY** need not be pressed if the cassette's record safety tab is removed.)

MAKE CONNECTION

1

Connect your VCR to an AV COMPU LINK component as shown in the illustration on page 19.

- The Mini-plug cable is a mono 3.5 mm mini-plug to mono 3.5 mm mini-plug connector.

TURN ON THE VCR

2

Press **POWER**.

ACCESS MAIN MENU SCREEN

3

Press **MENU**.

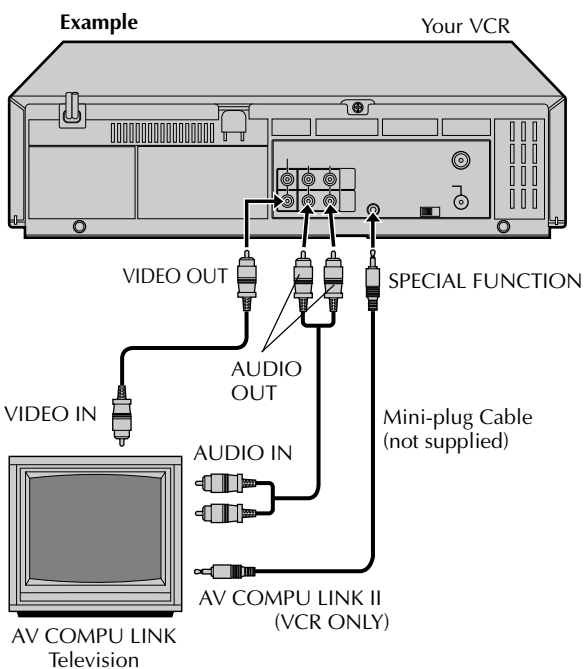
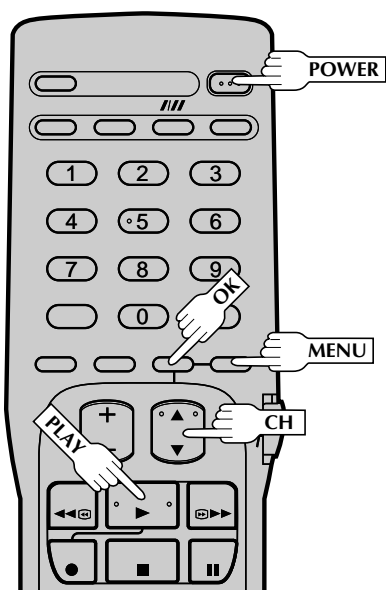
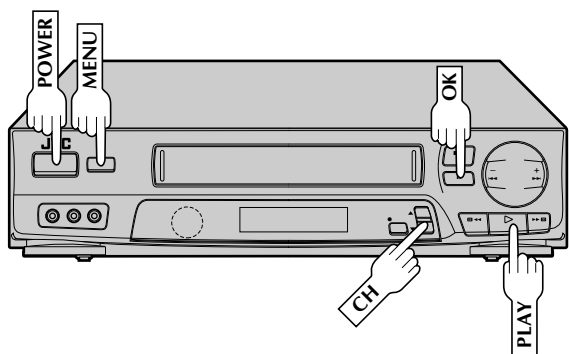

- 4 ACCESS FUNCTION SET SCREEN**
 Press **CH▲▼** to place the arrow next to "FUNCTION SET", then press **OK**.
- 5 ACCESS SPECIAL FUNCTION SCREEN**
 Press **CH▲▼** to place the arrow next to "SPECIAL FUNCTION", then press **OK**.

FUNCTION
 AUTO TIMER
 SUPERIMPOSE
 2ND AUDIO
 AUDIO MONITOR
 AUX INPUT
 AUTO SP/EP TIMER
 →SPECIAL FUNCTION
 PRESS (▲,▼), THEN (OK)
 PRESS (MENU) TO END
- 6 ENABLE AV COMPU LINK PLAYBACK**
 Press **CH▲▼** to place the arrow next to "AV COMPU LINK".

SPECIAL FUNCTION
 R.A. EDIT/PAUSE
 →AV COMPU-LINK

PRESS (▲,▼) TO SELECT
 PRESS (MENU) TO END
- 7 RETURN TO NORMAL SCREEN**
 Press **MENU** as many times as necessary.
- 8 PERFORM AV COMPU LINK PLAYBACK**
 Simply insert a cassette and press **PLAY** (if the cassette's record safety tab has been removed, playback begins automatically). Linked components are turned on, and the TV set to its VIDEO mode, automatically!

NOTE:
 Connection varies depending on the type of JVC TV you have. Please refer to the TV's instruction manual when making this connection.

B.E.S.T. Picture System

Your VCR is equipped with the B.E.S.T. (Biconditional Equalized Signal Tracking) feature, which checks the condition of the tape in use during recording and playback, and compensates to provide the highest-possible recording and playback pictures. *The default setting for both recording and playback is "ON".

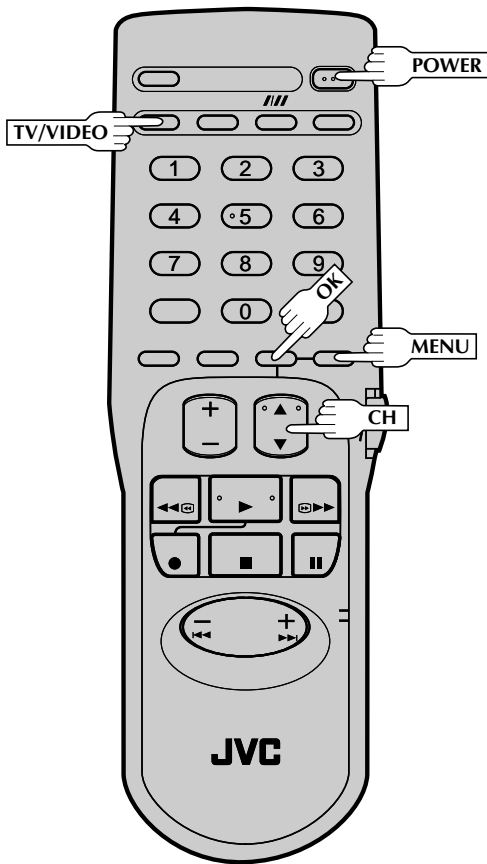
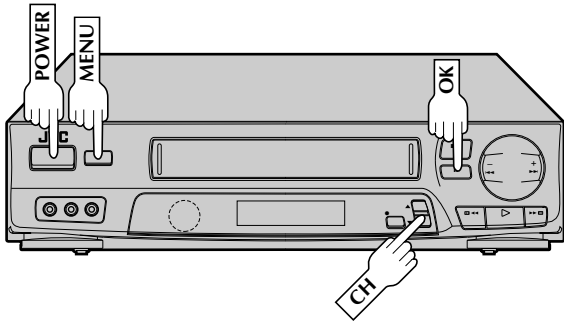

Preparation

1 TURN ON THE VCR

Press **POWER**. If watching channel 3 or 4, press **TV/VIDEO** to select the VIDEO mode. VIDEO is displayed on the front display panel.

2 ACCESS MAIN MENU SCREEN

Press **MENU**.

3 ACCESS B.E.S.T. PICTURE SYSTEM SCREEN

Press **CH▲▼** to place the arrow next to "B.E.S.T. PICTURE SYSTEM", then press **OK**.

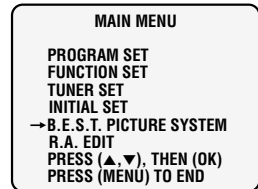

4 SELECT MODE

Place the arrow next to "ON" by pressing **CH▲▼**, then press **OK** to move the arrow to the Playback section. Set Playback to "ON", then press **MENU** as many times as necessary to return to the normal screen. (Pressing **OK** returns the arrow to the Recording section.)

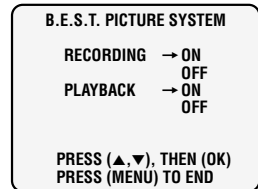

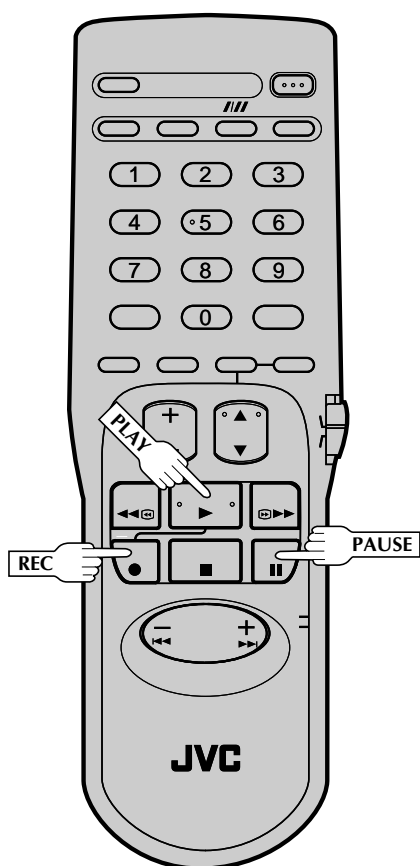
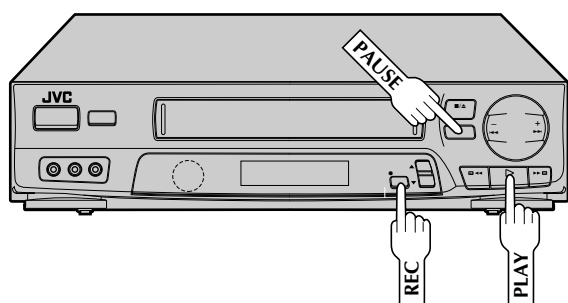

Recording

Perform steps 1 – 3 on page 11 ("Simple Recording") before continuing.

1

START RECORDING

Press and hold **REC** and press **PLAY** on the remote control, or press **REC** on the VCR's front panel.

- The VCR takes about 7 seconds to assess the quality of the tape in use, then recording begins with the picture level optimized.

NOTES:

- *B.E.S.T. occurs immediately prior to both the first SP and the first EP recording after inserting the cassette. It does not take place during recording.*
- *In the case of timer recording, B.E.S.T. takes place for both SP and EP before the first timer recording after inserting the cassette (regardless of the tape speed selected for that recording).*
- *Once the cassette is ejected, the B.E.S.T. data is canceled. The next time the cassette is used for recording, B.E.S.T. is re-performed.*
- *While B.E.S.T. is operative, the PAUSE button will not function.*
- *SUPERIMPOSE must be set to "ON" or the B.E.S.T. Picture System screen will not appear (☞ pg. 15).*

DURING B.E.S.T.

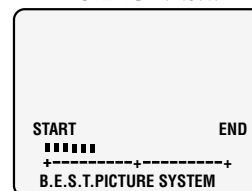

B.E.S.T. COMPLETE

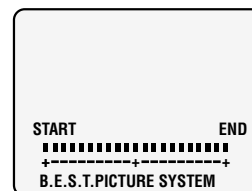

ATTENTION:

- As B.E.S.T. takes place before recording actually starts, there is a delay of about 7 seconds after **REC** and **PLAY** on the remote, or **REC** on the VCR's front panel, are pressed. To make sure you record the desired scene or program completely, first perform the following steps:
 - 1) Press and hold **PAUSE**, and press **REC** to engage the RECORD PAUSE mode.
 - The VCR then automatically checks the condition of the tape and, after about 7 seconds, re-enters RECORD PAUSE.
 - 2) Press **PLAY** to start recording.
 - If you want to bypass B.E.S.T. and start recording right away, set "RECORDING" to "OFF" in step 4 of the Preparation procedure (☞ pg. 20).

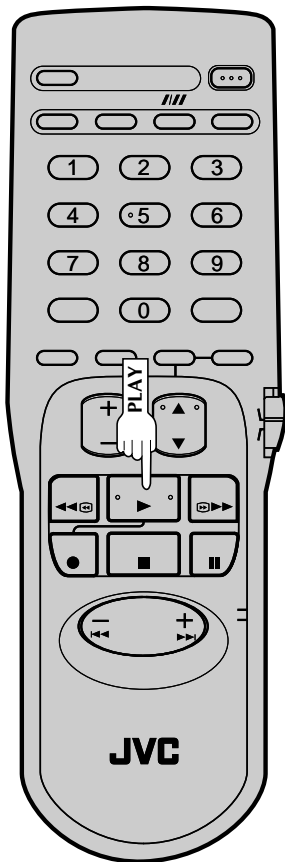
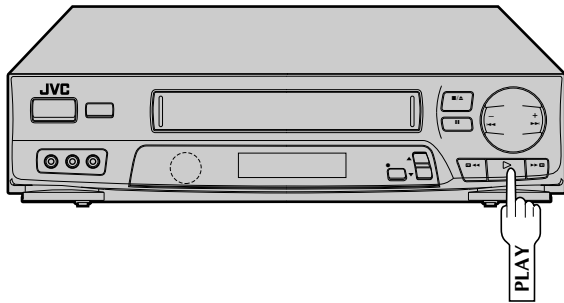

Playback

The VCR assesses the quality of the tape once you initiate playback.

Before beginning, perform steps 1 and 2 on page 10.

START PLAYBACK

1

Press **PLAY**.

- The VCR adjusts the playback picture quality based on the quality of the tape in use.

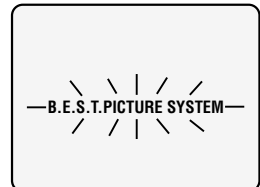

NOTES:

- When using rental tapes, or tapes recorded on other VCRs, set "PLAYBACK" in step 4 of the Preparation procedure to either "ON" or "OFF" as desired (☞ pg. 20).
- The B.E.S.T. Picture System screen only appears at the beginning of automatic tracking. Even though the screen doesn't appear after that, the B.E.S.T. function is operative.
- SUPERIMPOSE must be set to "ON" or the B.E.S.T. Picture System screen will not appear (☞ pg. 15).

Recording

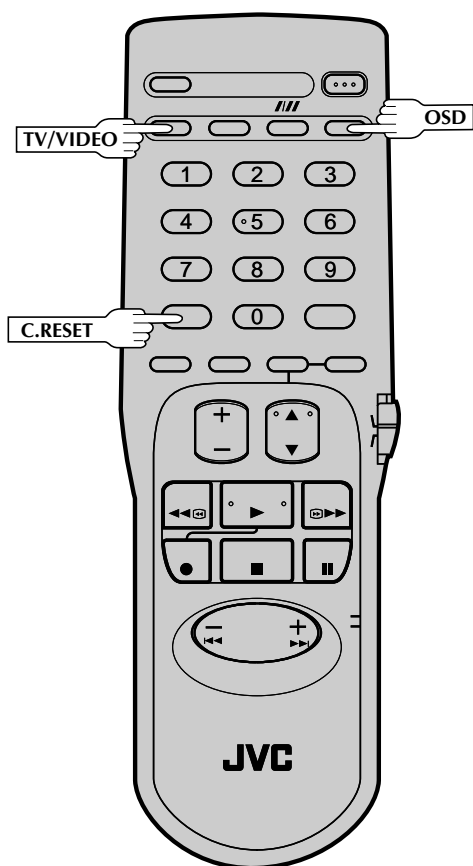
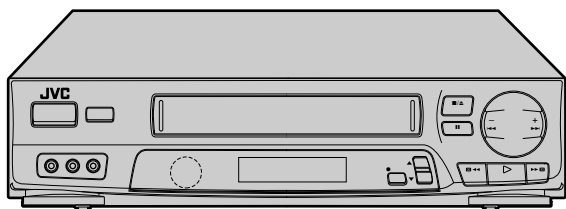

Record One Program While Watching Another

1 ENGAGE TV MODE

During recording...

- If using the RF connection (☞ pg. 4), press **TV/VIDEO**. The VCR's VIDEO indicator goes out and the TV broadcast being recorded disappears.
- If using the AV connection (☞ pg. 4), change the TV's input mode from AV to TV.

2 SELECT CHANNEL FOR VIEWING

Use the TV's channel selector to set the channel you want to watch.

Display Elapsed Recording Time

1 RESET COUNTER TO ZERO

Before recording starts, press **C.RESET**. The counter resets to zero and displays the exact elapsed time as the tape runs.

2 DISPLAY ELAPSED TIME ON SCREEN

During recording, press **OSD** at any time to see the elapsed time. All indications corresponding to the current status of the VCR are displayed for 5 seconds. The counter display remains on the screen indicating the elapsed time. Press **OSD** again to remove the display.

- Make sure "SUPERIMPOSE" is set to "ON" (☞ pg. 15).

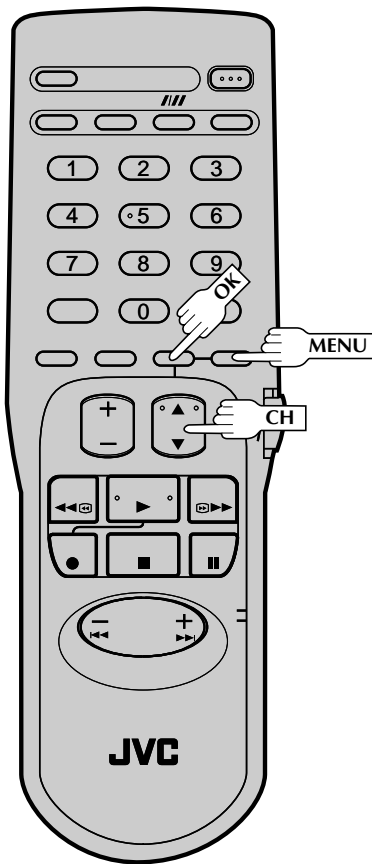
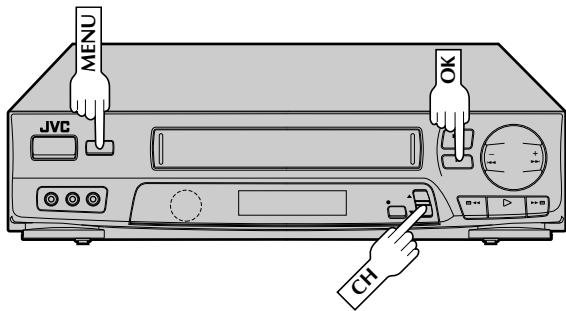

Stereo And SAP (Second Audio Program)

Your VCR's built-in MTS decoder enables reception of Multi-channel TV Sound broadcasts.

- The ST indicator on the front display panel lights during stereo broadcast reception, and SAP lights during SAP program reception.
- Both indicators light when a stereo program is accompanied by SAP audio.

To Record Stereo Programs . . .

. . . simply follow the basic recording procedure.

To Listen To Stereo Soundtrack During Recording . . .

. . . select "HI-FI" at the Audio Monitor screen (☞ pg. 14).

To Record SAP Programs . . .

1 ACCESS MAIN MENU SCREEN

Press MENU.

2 ACCESS FUNCTION SET SCREEN

Place the arrow next to "FUNCTION SET" by pressing CH▲▼, then press OK.

3 ACCESS 2ND AUDIO SCREEN

Place the arrow next to "2ND AUDIO" by pressing CH▲▼, then press OK.

4 SELECT MODE

Place the arrow next to "ON" by pressing CH▲▼.

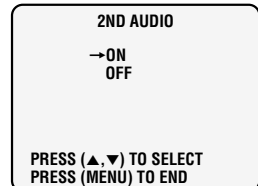

5 RETURN TO NORMAL SCREEN

Press MENU as many times as necessary.

NOTES:

- If a SAP program is received, the SAP audio is recorded on both the Normal and Hi-Fi tracks. The main audio program is not recorded.
- If a non-SAP program is received, the main audio is recorded on both the Hi-Fi and Normal audio tracks.

Instant Timer Recording (ITR)

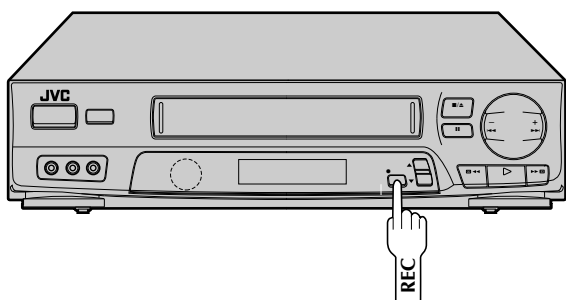

This easy method lets you record for from 30 minutes to 6 hours (selectable in 30-min. increments), and shuts the VCR off after recording is finished.

START RECORDING

1

Press **REC**.

ENGAGE ITR MODE

2

Press **REC** again. ITR blinks and 0:30 appears on the front display panel.

SET RECORDING DURATION

3

If you want to record for more than 30 minutes, press **REC** to extend the time. Each press extends recording time by 30 minutes.

NOTES:

- You can only perform ITR using the **REC** button on the VCR's front panel.
- After you set the time, the previous display reappears.
- To check remaining recording time, press **REC** once during recording and the remaining time is displayed for about 5 seconds. Be careful not to press again during this 5 seconds, or you'll add 30 more minutes to the recording.

On-Screen Timer Programming

* Refer to the illustration on page 26.

You can directly program the VCR's timer to record up to 8 shows, as far as a year in advance. Remember, the clock must be set before you can program the timer (☞ pg. 5).

LOAD A CASSETTE

1

Make sure the record safety tab is intact. If not, cover the hole with adhesive tape, then load.

- The VCR comes on, and the counter is reset, automatically.
- If watching channel 3 or 4, press **TV/VIDEO** to select the VIDEO mode. VIDEO is displayed on the front display panel.

ACCESS PROGRAM SET SCREEN

2

Press **MENU**, then press **OK**.

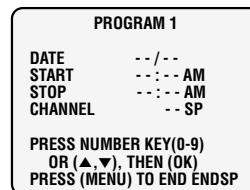

CONTINUED ON NEXT PAGE.

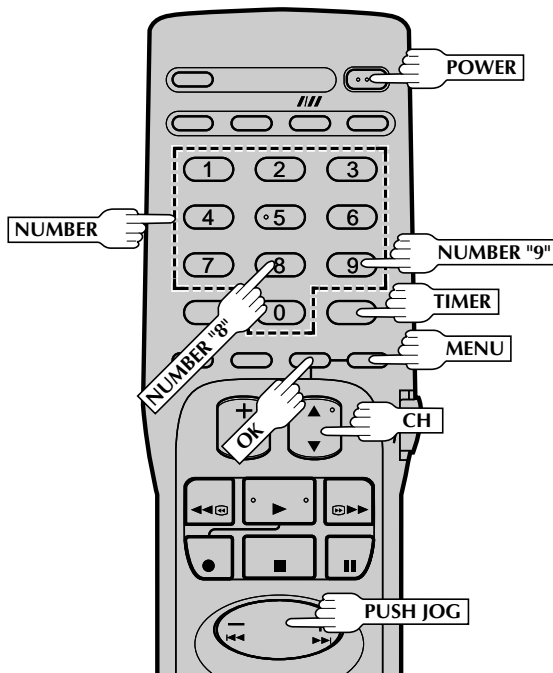
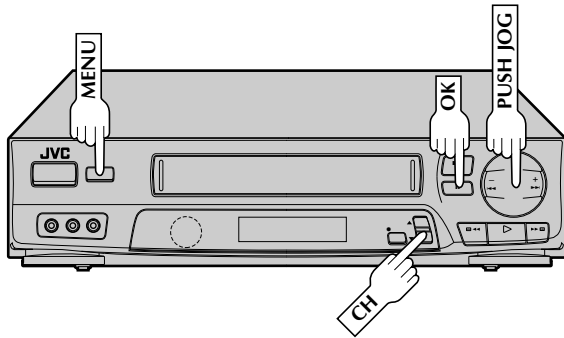

EXAMPLE

If you program the VCR to timer record a show on September 6 on channel 40 from 12:00 noon to 1:00 PM in SP mode, the screen will look like this:

PROGRAM 1	
DATE	9/6 SUN
START	12:00 PM
STOP	1:00 PM
CHANNEL	40 SP
PRESS NUMBER KEY(0-9) OR (▲, ▼), THEN (OK) PRESS (MENU) TO END	

NOTES:

- To disengage the timer before recording starts, press **TIMER** again. Pressing once more re-engages it.
- In case of a power failure after programming, the VCR's memory backup keeps your selections for 18 hours.
- If you select "PROGRAM SET" without having set the date and time, an error message appears. Follow its instructions.
- If you enter a start time that has already passed, **ERROR** appears on the screen and flashes.
- Programs that start after midnight must have the next day's date.

3

SELECT PROGRAM NUMBER

Press the appropriate **NUMBER** keys or **CH▲▼** to select a vacant program number, then press **OK**. The first time you do this, all numbers will be vacant, so just press **OK** when the screen appears.

4

SET PROGRAM INFORMATION

Press the appropriate **NUMBER** keys to set the date, start/stop time and channel number. Press **CH▲▼** to set AM/PM and tape speed. Then press **OK** after AM/PM, channel number and tape speed settings. The next setting that can be set begins flashing.

- Any information comprised of 1 digit (except the channel number) should have a "0" entered before it.
- It is possible to set all information using the **CH▲▼** buttons. (In this case, press **OK** after each setting.)

NOTE:

If you are using a cable box, enter the cable box channel, not the channel to be recorded. The channel to be recorded must be selected on the cable box. (The cable box channel is the VCR's channel that displays the channels received by the cable box.)

** You can record selected programs at the same time every weekday, or once a week. Before entering the month, press **NUMBER** key "8" (DAILY) or "9" (WEEKLY). Either "DAILY" or "WEEKLY" appears. Press again and "DAILY" or "WEEKLY" disappears.

5

MAKE CORRECTIONS

To change any of the settings, press **OK** or **PUSH JOG** ◀▶ until the item you want to change begins blinking. Then set as in step 4.

6

RETURN TO NORMAL SCREEN

Press **MENU** as many times as necessary.

7

ENGAGE TIMER MODE

Press **TIMER**. The VCR turns off automatically.

- After timer recording is completed, the VCR's power goes off automatically.
- You can program the timer while a regular recording is in progress; the on-screen menu will not be recorded.
- If the end of tape is reached during timer recording, the cassette is automatically ejected.
- When timer-recording cable channels received through a Cable Box, be sure to keep the Cable Box set to ON.

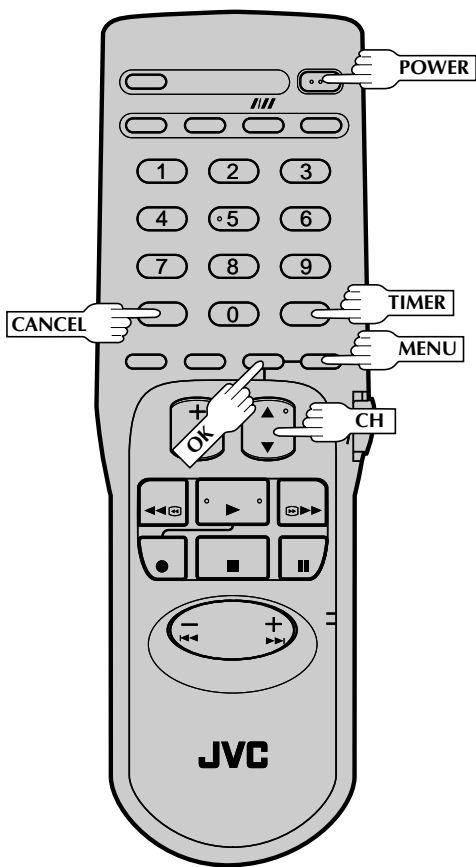
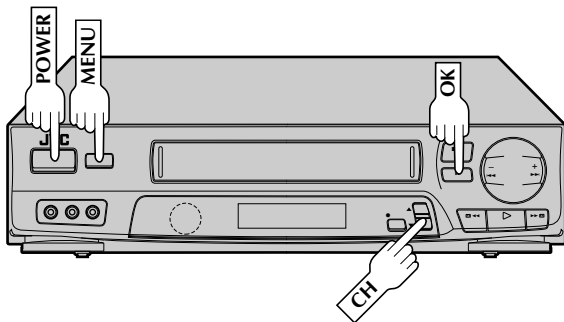

Check And Cancel Programs

1

DISENGAGE TIMER

Press **TIMER**, then press **POWER**.

2

ACCESS PROGRAM SET SCREEN

Press **MENU**, then press **OK**.

3

CHECK PROGRAM INFORMATION

Press **CH▲▼** to check the programs in succession.

To Cancel A Program . . .

4

CANCEL A PROGRAM

Press **CANCEL**.

- Repeat steps 3 and 4 as many times as necessary.

5

RETURN TO NORMAL SCREEN

Press **MENU** as many times as necessary. If there are still programs remaining, go to step 6.

6

RE-ENGAGE TIMER

Press **TIMER** again.

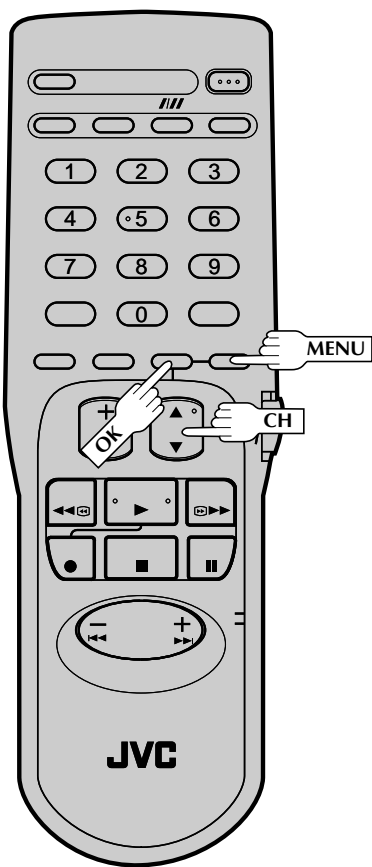
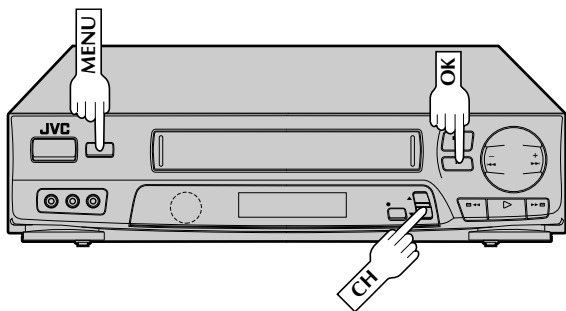

NOTES:

- If you have programmed the VCR to timer-record 2 or more programs, the second program and those thereafter may not fit on the tape if you set the Auto SP/EP Timer mode to "ON". In this case, make sure the mode is not engaged, then set the tape speed manually during timer programming.
- There may be some noise at the point on the tape where the VCR switches from SP to EP mode.
- The Auto SP/EP Timer feature is not available during ITR (Instant Timer Recording), and the feature will not work properly with any tapes other than the following: T-30, T-60, T-90, and T-120.

Auto SP/EP Timer

If, when recording in SP mode, there is not enough tape to record the entire program, the VCR automatically switches to EP mode to allow complete recording. This feature is especially handy when recording a program of more than 2 hours in length.

For Example . . .

Recording a program of 140 minutes in length onto a 120-minute tape

Approximately 110 minutes	Approximately 30 minutes
SP mode	EP mode
Total 140 minutes	

Make sure you select "ON" at the Auto SP/EP Timer screen before performing timer programming.

1 ACCESS MAIN MENU SCREEN

Press MENU.

2 ACCESS FUNCTION SET SCREEN

Place the arrow next to "FUNCTION SET" by pressing CH▲▼, then press OK.

3 ACCESS AUTO SP/EP TIMER SCREEN

Place the arrow next to "AUTO SP/EP TIMER" by pressing CH▲▼, then press OK.

4 SELECT MODE

Place the arrow next to your choice ("ON" or "OFF") by press CH▲▼.

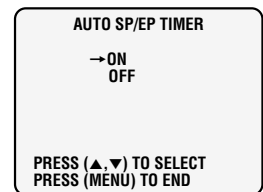

5 RETURN TO NORMAL SCREEN

Press MENU as many times as necessary.

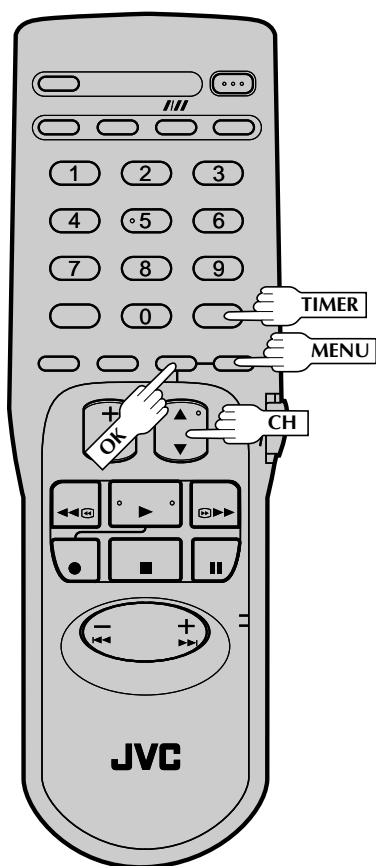
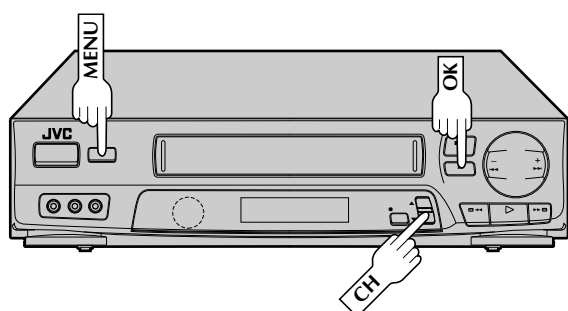

Auto Timer

When activated, this function automatically engages the timer when the VCR's power is turned off, and disengages it when the power is turned on.

1 ACCESS MAIN MENU SCREEN

Press **MENU**.

2 ACCESS FUNCTION SET SCREEN

Place the arrow next to "FUNCTION SET" by pressing **CH▲▼**, then press **OK**.

3 ACCESS AUTO TIMER SCREEN

Place the arrow next to "AUTO TIMER" by pressing **CH▲▼**, then press **OK**. Now skip to step 2 of the procedure below.

Or, during on-screen timer programming ...

1 ACCESS AUTO TIMER SCREEN

In step 5 in the On-Screen Timer Programming procedure (pg. 26), press **MENU**.

2 SELECT MODE

Place the arrow next to your choice ("ON" or "OFF") by pressing **CH▲▼**.

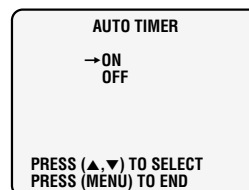

3 RETURN TO NORMAL SCREEN

Press **MENU** as many times as necessary.

NOTE:

For safety, when **AUTO TIMER** is set to "OFF", all other VCR functions are disabled while the Timer mode is engaged. To disengage the timer, press **TIMER**.

Edit From A Camcorder

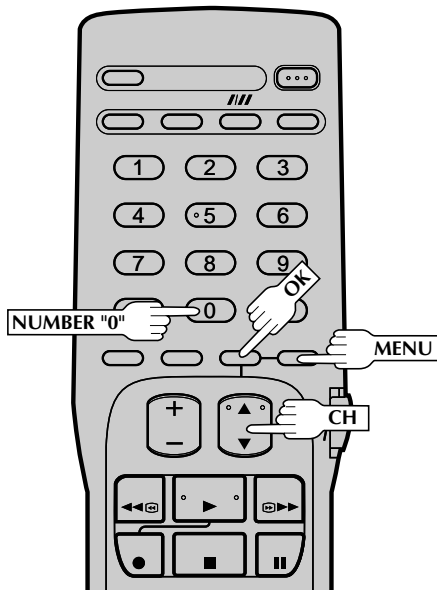
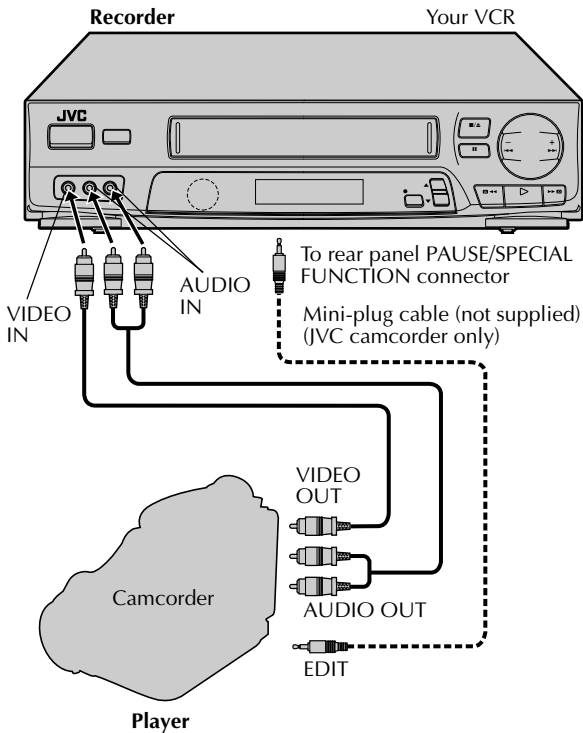

You can use a camcorder as the player and your VCR as the recorder.

1 MAKE CONNECTIONS

Connect an AV cable (not supplied) between the camcorder's VIDEO OUT and AUDIO OUT connectors and your VCR's VIDEO IN and AUDIO IN connectors.

- When a Master Edit Control-equipped JVC camcorder is used, the camcorder is capable of controlling your VCR. The Mini-plug cable is a mono 3.5 mm mini-plug to mono 3.5 mm mini-plug connector.

2 LOAD A CASSETTE

Insert the cassette to be recorded on into the recorder.

3 SET RECORDER'S INPUT MODE

Press NUMBER key "0" to set to AUX.

4 ACCESS MAIN MENU SCREEN

Press MENU.

5 ACCESS FUNCTION SET SCREEN

Press CH▲▼ to place the arrow next to "FUNCTION SET", then press OK.

*If you're using a JVC Master Edit Control-equipped camcorder — step 6
If not — step 9*

6 ACCESS SPECIAL FUNCTION SCREEN

Press CH▲▼ to place the arrow next to "SPECIAL FUNCTION", then press OK.

7 SELECT MODE

Press CH▲▼ to place the arrow next to "R.A. EDIT/PAUSE".

SPECIAL FUNCTION
→R.A. EDIT/PAUSE
AV COMPU-LINK

PRESS (▲, ▼) TO SELECT
PRESS (MENU) TO END

8 RETURN TO FUNCTION SET SCREEN

Press MENU.

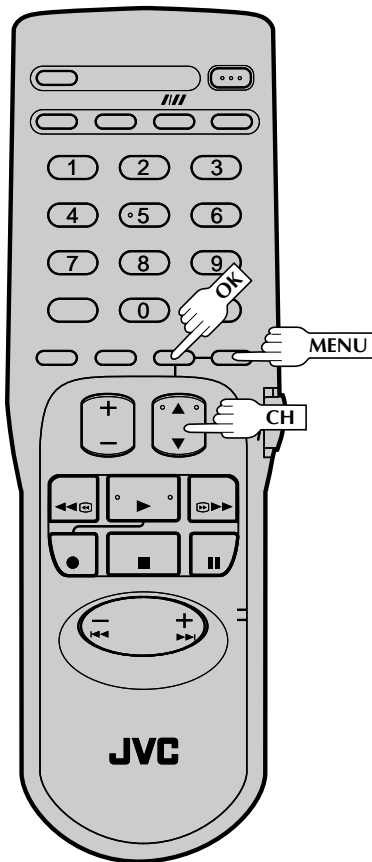
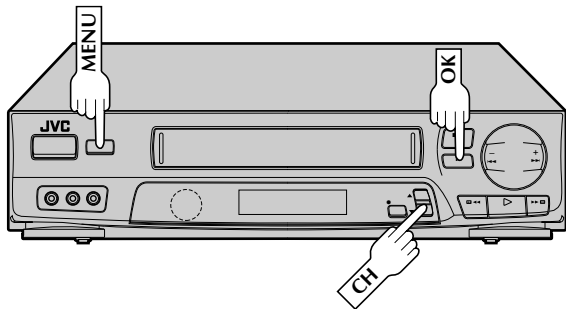

9 ACCESS AUX INPUT SCREEN

Press **CH▲▼** to place the arrow next to "AUX INPUT", then press **OK**.

10 SELECT INPUT

If you are connecting the AV cable to the AV connectors on the front of the VCR, place the arrow next to "FRONT" by pressing **CH▲▼**. If you are connecting the AV cable to the AV connectors on the back of the VCR, place the arrow next to "REAR" by pressing **CH▲▼**.

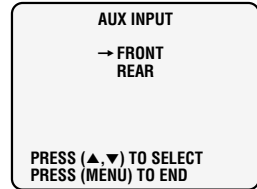

11 RETURN TO NORMAL SCREEN

Press **MENU** as many times as necessary.

12 START PLAYER

Set the camcorder to its play mode.

13 START RECORDER

Set your VCR to its record mode.

- If you are using a Master Edit Control-equipped JVC camcorder, it can put the recorder automatically into Record mode. (Refer to camcorder's instruction manual.)

Edit To Or From Another VCR

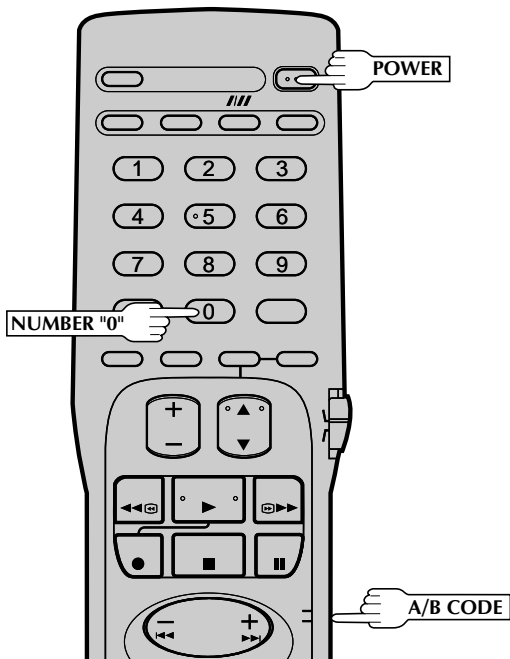
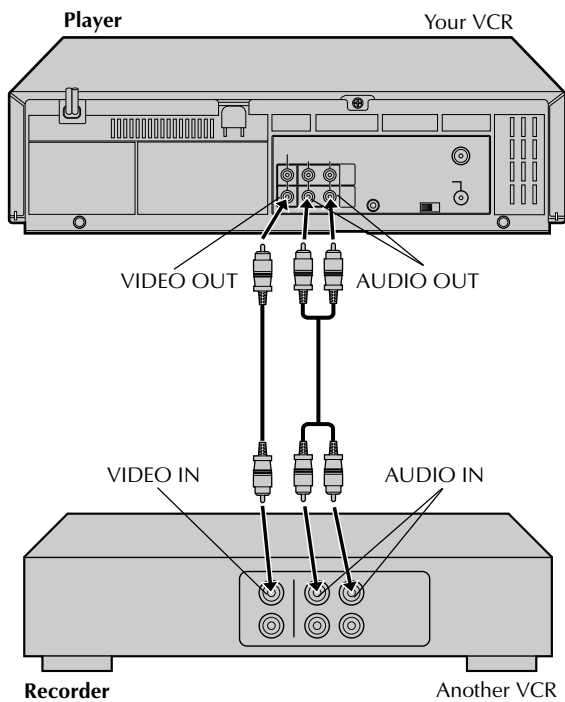

You can use your VCR as the player or the recorder.

1 MAKE CONNECTIONS

Connect an AV cable (not supplied) between the player's VIDEO OUT and AUDIO OUT connectors and the recorder's VIDEO IN and AUDIO IN connectors.

- When using your VCR as the recorder and a monaural VCR as the player, connect the player's AUDIO OUT connector to the AUDIO IN L connector on the recorder.

2 LOAD CASSETTES

Insert the playback cassette into the player and the cassette to be recorded on into the recorder.

3 SET RECORDER'S INPUT MODE

Set to AUX. With this VCR, press **NUMBER** key "0" (AU appears on the front display panel in place of a channel number).

NOTE:

When using this VCR as the recorder, make sure to select "FRONT" or "REAR" (depending on which input connectors you use) at the Aux Input Screen. (To select the correct AUX input connector, follow steps 4, 5, 9 – 11 from the "Edit From A Camcorder" section, pg. 30.)

4 START PLAYER

Set to its play mode.

5 START RECORDER

Set to its record mode.

Control Two JVC VCRs

The supplied remote control is capable of controlling two JVC VCRs independently using the **A/B CODE** switch. You can set this VCR so it responds to remote commands only when the switch is set to **B**, and another VCR so it responds to commands when the switch is set to **A**. The switch is preset to **A** because this VCR normally responds to A-code signals. You can easily modify this VCR to accept B-code commands.

- 1 Unplug the VCR's power cord from the AC outlet.
- 2 Set the **A/B CODE** switch on the remote control to **B**.
- 3 Plug the VCR's power cord back into the AC outlet.
- 4 Turn the VCR's power back on by pressing **POWER** on the remote.

The VCR will now respond only to B-code commands.

Random Assemble Editing

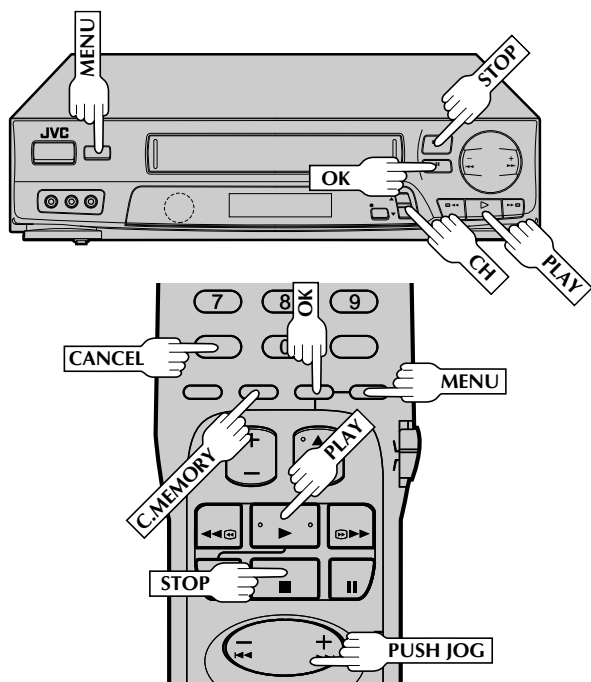
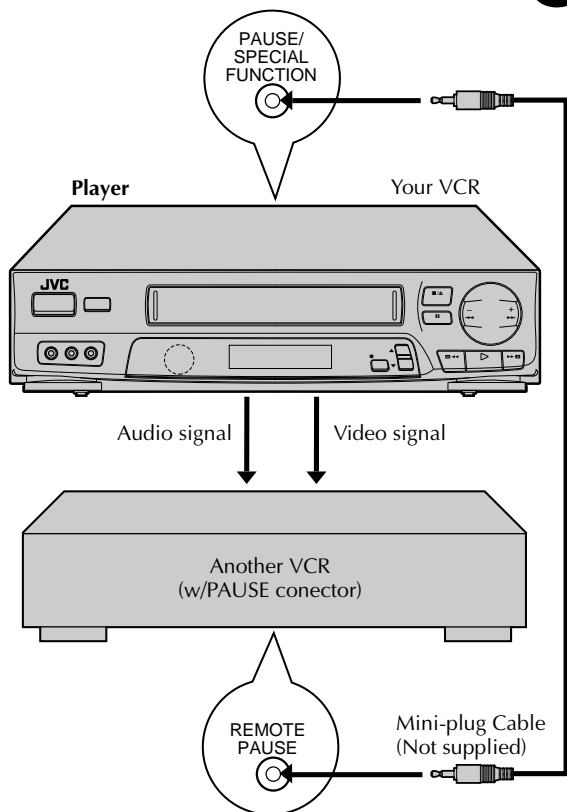

This function makes it easier to create edited videos when your VCR is used as the source player in combination with another VCR equipped with a Remote PAUSE Connector. You can pre-program up to 8 scenes or "cuts" for automatic editing in the sequence you have specified.

1 MAKE CONNECTIONS

Connect your VCR's VIDEO OUT and AUDIO OUT connectors to the VIDEO IN and AUDIO IN connectors on the recording deck, and connect your VCR's PAUSE/SPECIAL FUNCTION connector to the PAUSE connector on the recording deck.

- If the recording deck doesn't have a PAUSE connector, connect to the R.A. EDIT connector instead.
- The Mini-plug cable is a mono 3.5 mm mini-plug to mono 3.5 mm mini-plug connector.

2 PREPARE FOR EDITING

Perform steps 2 – 8 on page 30, "Edit From A Camcorder".

NOTE:

If you mistakenly select "AV COMPU LINK" in step 7 on page 30, an error message appears when you finish step 6. Make sure "R.A. EDIT/PAUSE" is selected before you continue.

-ERROR-
CHOOSE SPECIAL FUNCTION ON MAIN MENU AND SELECT R.A. EDIT/PAUSE

BEFORE YOU BEGIN R.A. EDIT

PRESS (MENU) TO MAIN MENU

3 LOAD SOURCE CASSETTE

Insert the source cassette into your VCR.

- To return to the normal screen from the Function screen, press **MENU**.

4 START SOURCE PLAYBACK

Press **PLAY**.

5 ACCESS MAIN MENU SCREEN

Press **MENU** to bring up the Main Menu screen.

6 ACCESS R.A. EDIT SCREEN

Place the arrow next to "R.A. EDIT" by pressing **CH▲▼**, then press **OK**.

- The screen is superimposed on the video playback in step 7.

MAIN MENU

PROGRAM SET
FUNCTION SET
TUNER SET
INITIAL SET
B. E. S. T. PICTURE SYSTEM
→ R.A. EDIT
PRESS (▲, ▼), THEN (OK)
PRESS (MENU) TO END

CONTINUED ON NEXT PAGE.

Refer to the illustrations on page 33.

7

LOCATE EDIT-IN POINT

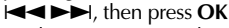
Find the point on the source tape from where you want the edited scene to begin by pressing **PUSH JOG** , then press **OK** on the remote control.

- The **OK** button on the VCR itself functions the same as the **PAUSE** button, so be sure to press the **OK** button on the remote.
- The edit-in point is registered in memory and appears on the screen.
- You can also perform an Index Search (if index marks have been previously recorded on the tape at the desired points  pg. 16) to find the points you want, but this will result in reduced accuracy.

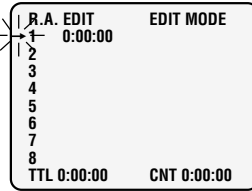

8

LOCATE EDIT-OUT POINT

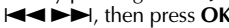
Find the point where you want the edited scene to end by pressing **PUSH JOG** , then press **OK** on the remote control.

- The **OK** button on the VCR itself functions the same as the **PAUSE** button, so be sure to press the **OK** button on the remote.
- The edit-out point is registered in memory and appears on the screen.
- The total time of the edited scenes is displayed to the right of "TTL".
- Repeat steps 7 and 8 for each additional scene.

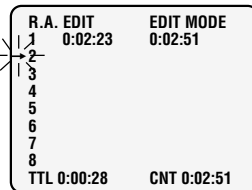
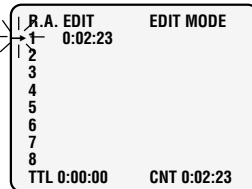

9

PREPARE RECORDING DECK

Engage its Record-Standby mode.

10

START R.A. EDIT

Press **C.MEMORY**.

- Automatic editing begins; all the specified scenes are copied to the recording deck in the order they were registered.
- The on-screen display remains while your VCR searches for each scene (blinking cursor indicates scene currently being searched for), but disappears during actual editing.
- During scene search, the recording deck automatically enters its Record-Standby mode. "SEARCHING" appears on the screen.
- When all registered scenes have been edited, your VCR enters the Stop mode, the recording deck enters its Record-Standby mode, a blue background replaces the video playback (behind the R.A. Edit screen), and the cursor blinks at the next available number.

11

END R.A. EDIT

Press **MENU** as many times as necessary to return to the normal screen, and engage the Stop mode for the recording deck.

NOTES:

- You can also monitor the sound when searching for scenes you want to edit in steps 7 – 8. Since you can hear the soundtrack during selection, you can avoid abrupt or unnatural sounding scene-to-scene transitions.
- When editing, there may be a discrepancy of about 2 seconds on the source tape between the locations you chose as edit-in/-out points and the locations the VCR recognizes as those points.
- For any scene, the edit-out point must have a counter reading that is at least 1 second after the corresponding edit-in point. Any less than 1 second and the edit-out point will not be registered.
- Since the source VCR prerolls during Random Assemble Editing, there must be at least 15 seconds worth of recorded material prior to any edit-in point on the source tape.
- If the search time for an edit-in point exceeds 5 minutes, the recording deck enters its Stop mode and editing will not take place.

To Make Corrections . . .

. . . during step 7 or 8, you can cancel registered in and out points by pressing **CANCEL** on the remote control. Each time you press, the preceding point is erased.

- If, for example, you have registered 5 sets of in and out points and want to reset the first set, you have to press **CANCEL** until all points after the first set have been erased. Reenter them after you've repaired the first set of points.

Memory Capacity

Random Assemble Editing shares memory space with the VCR's timer. If there are programs occupied by timer-recording data, those spaces cannot be used to register edit-in and -out points — meaning you won't be able to edit 8 scenes.

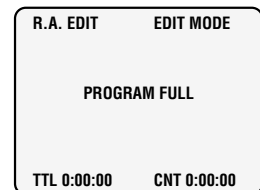

- When all 8 programs are full, "PROGRAM FULL" appears on the R.A. EDIT screen.
- To cancel a program, see page 27.

RM-V403U Multi-Brand R.A. Edit Controller (Not supplied)

By connecting this controller to your VCR's R.A. EDIT connector, you can perform Random Assemble Editing in combination with a second non-JVC VCR. The controller is compatible with various major VCR brands. For compatible systems and availability, please consult your JVC dealer.

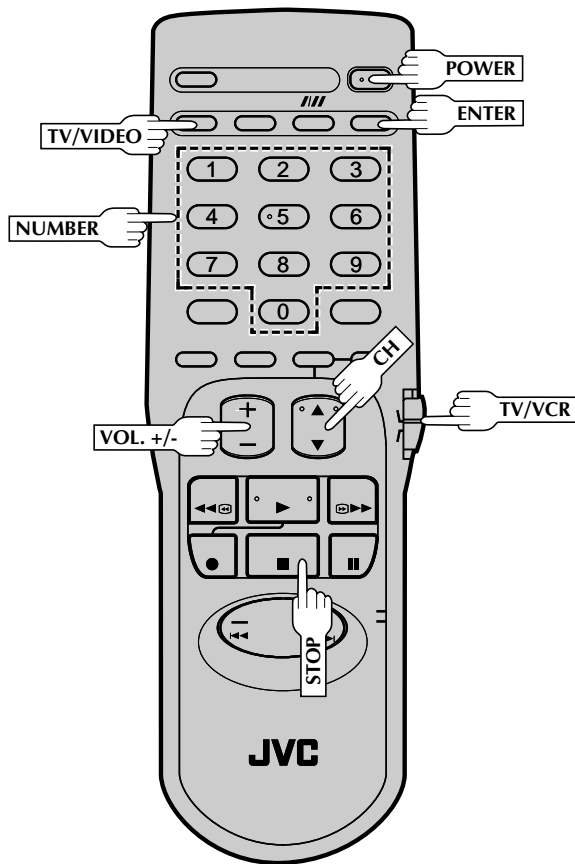

TV Multi-Brand Remote Control

The VCR's remote control can control several functions on JVC remote control TVs and on the brands of remote control TVs listed below. Some TV brands have more than one code. If the TV will not function with one code, try entering another.

1

TURN ON THE TV

Turn the power on using the TV's remote control.

2

SET REMOTE CONTROL MODE

Set the TV/VCR switch on the VCR's remote control to TV.

3

SET TV BRAND CODE

Refer to the chart below. While holding down **POWER**, enter your TV's brand code using the **NUMBER** keys, then press **STOP**.

- Once you have set the remote control to operate the TV, you don't have to repeat this step until you replace your remote control's batteries.

4

OPERATE TV

First, press **POWER** on the remote to see if the TV's power goes off as it should. If it does, try other operations.

- The **POWER**, **TV/VIDEO**, **CH▲▼**, **VOL +/-** and **NUMBER** keys on the remote can all be used to operate the TV. *For some brands of TV, you must press **ENTER** after having pressed the **NUMBER** keys.
- To return the remote to VCR control, set the **TV/VCR** switch to **VCR**.

NOTE:

Depending on the kind of TV, there may be cases where some or all functions cannot be operated using the remote control.

TV BRAND NAME	BRAND CODE
JVC	01
PHILIPS	03
PHILICO/HITACHI	05
SHARP	06
TOSHIBA	07
MITSUBISHI	08
PHILICO/DAEWOO	09
PACKARD BELL	09
KIOTE/DAEWOO	09
DAEWOO	10
SAMSUNG	11
GOLDSTAR	12
RCA	14
PANASONIC	15, 16
SONY	18
ZONDA	19, 20, 21
AKAWA	21, 22
ELECTRA	23
PHILICO	25

Before requesting service for a problem, use this chart and see if you can repair the trouble yourself. Small problems are often easily corrected, and this can save you the trouble of sending your VCR off for repair.

POWER		
SYMPTOM	POSSIBLE CAUSE	CORRECTIVE ACTION
1. The power won't come on.	<ul style="list-style-type: none"> • The power cord is disconnected. 	Connect the power cord.
2. The clock works, but the VCR's power won't come on.	<ul style="list-style-type: none"> • The TIMER mode is engaged with Auto Timer set to "OFF" (☞ pg. 29). 	Press TIMER to disengage.
3. The remote control won't function.	<ul style="list-style-type: none"> • The batteries are discharged. • The A/B CODE switch is in the wrong position. • The TV/VCR switch is in the wrong position. 	Replace the dead batteries with new ones. Re-perform the A/B Code setting (☞ pg. 32). Set the switch to the position corresponding with the unit you want to operate.
TAPE TRANSPORT		
SYMPTOM	POSSIBLE CAUSE	CORRECTIVE ACTION
1. The cassette gets stuck partway during loading, and is ejected.	<ul style="list-style-type: none"> • The cassette was inserted incorrectly. 	Make sure the window side is up, the rear label side is facing you and the arrow on the front of the cassette is pointing towards the VCR. Then insert the cassette.
2. The tape stops during rewind or fast forward.	<ul style="list-style-type: none"> • The Counter Memory indicator ("M") is lit on the front display panel. 	Press C.MEMORY to disengage the Counter Memory mode and extinguish the indicator.
PLAYBACK		
SYMPTOM	POSSIBLE CAUSE	CORRECTIVE ACTION
1. The tape is running but the picture won't appear.	<ul style="list-style-type: none"> • If you're using the RF OUT connection (☞ pg. 4), the channel selector on the TV is set incorrectly. • If you're using the AV connection (☞ pg. 4), the TV receiver is set to the wrong mode. 	Set the channel selector to channel 3 or 4. Set the TV receiver to its AV mode.
2. Noise appears during visual search.	<ul style="list-style-type: none"> • This is normal. 	
3. Breaks are noticeable in Hi-Fi soundtrack.	<ul style="list-style-type: none"> • Automatic tracking is engaged. 	Engage and adjust tracking manually (☞ pg. 13).
4. The playback picture is blurred or interrupted, even though TV broadcasts are clear.	<ul style="list-style-type: none"> • The video heads may be dirty. 	The heads must be cleaned. Consult your JVC dealer.
5. The Hi-Fi soundtrack cannot be heard.	<ul style="list-style-type: none"> • The AUDIO MONITOR option at the Function Set screen was set incorrectly. 	Set AUDIO MONITOR to "HI-FI" (☞ pg. 14).
RECORDING		
SYMPTOM	POSSIBLE CAUSE	CORRECTIVE ACTION
1. Recording won't start.	<ul style="list-style-type: none"> • There's no cassette loaded. • The loaded cassette has had its record safety tab removed. 	Insert a cassette. Remove the cassette and cover the hole with adhesive tape, or load a cassette on which the record safety tab is intact.



2. TV broadcasts won't record properly.	<ul style="list-style-type: none"> • The VCR has been set to its AUX mode by mistake. 	Set the VCR to the appropriate channel.
3. Tape-to-tape editing won't work.	<ul style="list-style-type: none"> • The VCRs or the camcorder and the VCR have been incorrectly connected. • The power to one or more of the units has not been turned on. • The recorder's input mode has been set incorrectly. 	<p>Refer to the directions and the illustration under "Edit To And From Another VCR" (☞ pg. 32) or "Edit From A Camcorder" (☞ pg. 30) and properly connect the units. Make sure the power to all units is on.</p> <p>Set the recorder's input mode to AUX and select "FRONT" or "REAR" at the Aux Input Screen (☞ pg. 31).</p>

TIMER RECORDING

SYMPTOM	POSSIBLE CAUSE	CORRECTIVE ACTION
1. Timer recording won't work.	<ul style="list-style-type: none"> • The clock and/or the timer have been set incorrectly. • The timer is not engaged. • The VCR has not been set up properly. 	Check or re-perform the clock/timer settings to ensure correctness. Press TIMER and check to make sure that TIMER appears on the front display panel. Re-perform the set-up procedures.
2. On-screen timer programming won't work.	<ul style="list-style-type: none"> • Timer recording is in progress. 	Timer programming can't be performed when timer recording is in progress. Wait until it finishes.
3. TIMER and [] on the front display panel won't stop blinking.	<ul style="list-style-type: none"> • The timer is engaged but there's no cassette loaded. 	Load a cassette with the record safety tab intact, or with the hole covered with adhesive tape.
4. The cassette is automatically ejected, and TIMER and [] on the front display panel won't stop blinking.	<ul style="list-style-type: none"> • The loaded cassette has had its record safety tab removed. 	Remove the cassette and cover its hole with adhesive tape, or replace it with a cassette on which the safety tab is intact.
5. TIMER blinks for 10 seconds and the timer mode is disengaged.	<ul style="list-style-type: none"> • TIMER has been pressed when there are no programs in memory, or the timer record program information has not been programmed correctly. 	Check the programmed data and re-program as necessary, then press TIMER again.
6. The cassette is automatically ejected, the power shuts off and TIMER and [] won't stop blinking.	<ul style="list-style-type: none"> • The end of tape was reached during timer recording. 	The program may not have been recorded in its entirety. Next time make sure you have enough time on the tape to record the entire program.

OTHER PROBLEMS

SYMPTOM	POSSIBLE CAUSE	CORRECTIVE ACTION
1. When scanning channels, some of them are skipped over.	<ul style="list-style-type: none"> • Those channels have been preset to be skipped. 	If you need the skipped channels, restore them (☞ pg. 9).
2. The channel can't be changed.	<ul style="list-style-type: none"> • Recording is in progress. 	Press PAUSE to pause the recording, change channels, then press PLAY to resume recording.
3. The remote control won't operate my TV.	<ul style="list-style-type: none"> • The TV/VCR switch is set to a position other than TV. 	Set the switch to TV.

ATTENTION:

This recorder contains microcomputers. External electronic noise or interference could cause malfunctioning. In such cases, switch the power off and unplug the power cord. Then plug it in again and switch power on. Take out the cassette. After checking the cassette, operate the unit as usual.



PLAYBACK

Q. What happens if the end of the tape is reached during playback or search?

A. The tape is automatically rewound to the beginning.

Q. Can the VCR indefinitely remain in the still mode?

A. No. It stops automatically after 5 minutes to protect the heads.

Q. During search, slow, still and frame-by-frame playback, I can't hear any audio. What's the problem?

A. This is normal.

Q. During search, still and frame-by-frame playback, the picture is intermittent. What's the cause?

A. Picture loss occurs when these types of playback are attempted with a tape recorded in LP mode. Pressing **PLAY** to return to normal playback will restore the picture.

Q. When returning from multi-speed search to normal playback, the picture is disturbed. Should I be concerned about this?

A. No, it is normal.

Q. Noise bars appear during multi-speed search. What's the problem?

A. This is normal.

Q. Other than preventing further recording, what effect does removing the safety tab have?

A. It disables marking of index codes.

Q. Sometimes, during Index Search, the VCR can't find the program I want to see. Why not?

A. There may be index codes too close together.

Q. During playback, on-screen operational indicators sometimes jitter. Why does this happen?

A. If the condition of the tape being played back is not good, jittering of the video (including on-screen indicators) may occur.

RECORDING

Q. When I pause and then resume a recording, the end of the recording before the pause is overlapped by the new recording. Why does this happen?

A. This is normal. It reduces distortion at the pause and resume points.

Q. Can the VCR indefinitely remain in the Record-Pause mode?

A. No. The VCR automatically goes to its Stop mode after 5 minutes to protect the heads. When paused during Instant Timer Recording (ITR), the VCR shuts off automatically after 5 minutes.

Q. What happens if the tape runs out during recording?

A. The VCR automatically rewinds it to the beginning.

TIMER RECORDING

Q. REC and TIMER remain lit on the front display panel. Is there a problem?

A. No. This is a normal condition for a timer recording in progress.

Q. Can I program the timer while I'm watching a tape or a TV broadcast?

A. You won't see the picture as it is replaced by the on-screen menu, but the audio from the program or tape you're viewing is present.





List Of Terms

This guide serves as a quick way to locate frequently used terms and on-screen display names. The first page on which the term appears is listed. Most terms appear more than once in the instruction manual.

A

A/B Code	32
Add Channel	9
AFC	9
Audio Monitor	14
Auto Channel Setting	8
Auto SP/EP Timer	28
Auto Timer	29
Automatic Tracking	13
Aux Input	31
AV Compu Link Playback	18
AV Connection	4

B

Band	7
B.E.S.T. Picture System	20

C

Cancel Program	27
Cassette Adapter.....	10
Check Program	27
Clock Setting	6
Connection to TV	4
Contents	3
Counter Memory	17
Counter Reset	17

D

Delete Channel	9
----------------------	---

E

Editing.....	30
--------------	----

F

Fast Motion Playback	12
Frame-by-Frame Playback	12
Function Setting	14

I

Index Search	16
Insert Cassette	10
Instant ReView	17
ITR (Instant Timer Recording)	25

L

Language Selection	5
--------------------------	---

M

Main Menu	5
Manual Channel Setting	9
Manual Tracking	13
MBR (Multi-Brand Remote) Code Setting	35

N

Next-Function Memory	18
----------------------------	----

O

On-Screen Display	15
-------------------------	----

P

Playback	10
Program Setting	25
Push Jog	12

R

Random Assemble Editing	33
Record Safety Tab	11
Recording	11
Repeat Playback	16
Reverse Motion Playback	12
Reverse Playback	12
Reverse Slow Motion Playback	12
RF Connection	4

S

SAP (Second Audio Program)	24
Second Audio	24
Skip Search	16
Slow Motion Playback	12
Specifications	42
Still Playback	12
Superimpose	15

T

Tape Position Indicator	18
Tape Speed Setting	11
Timer Programming	25
Timer Recording	25
Tuner Setting	7

FRONT VIEW

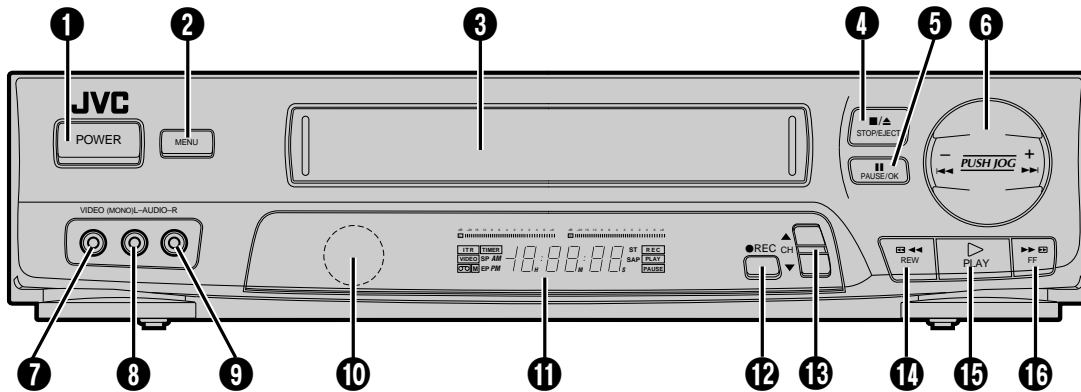

- 1 POWER ON/OFF Button (☞ pg. 5)
- 2 MENU Button (☞ pg. 5)
- 3 Cassette Loading Slot
- 4 STOP/EJECT Button (☞ pg. 10)
- 5 PAUSE Button (☞ pg. 11)
OK Button (☞ pg. 5)
- 6 PUSH JOG Button (☞ pg. 12)
- 7 Video Input Connector (☞ pg. 30)
- 8 Mono Audio Input Connector (☞ pg. 30)
Audio Input Connector [L] (☞ pg. 30)
- 9 Audio Input Connector [R] (☞ pg. 30)
- 10 Remote Control Sensor
- 11 Front Display Panel (☞ pg. 41)
- 12 Record [REC] Button (☞ pg. 11)
- 13 Channel ▲▼ Buttons (☞ pg. 5)
- 14 Rewind [REW] Button (☞ pg. 10)
Reverse Search Button (☞ pg. 12)
- 15 PLAY Button (☞ pg. 10)
- 16 Fast-Forward [FF] Button (☞ pg. 10)
Forward Search Button (☞ pg. 12)

REAR VIEW

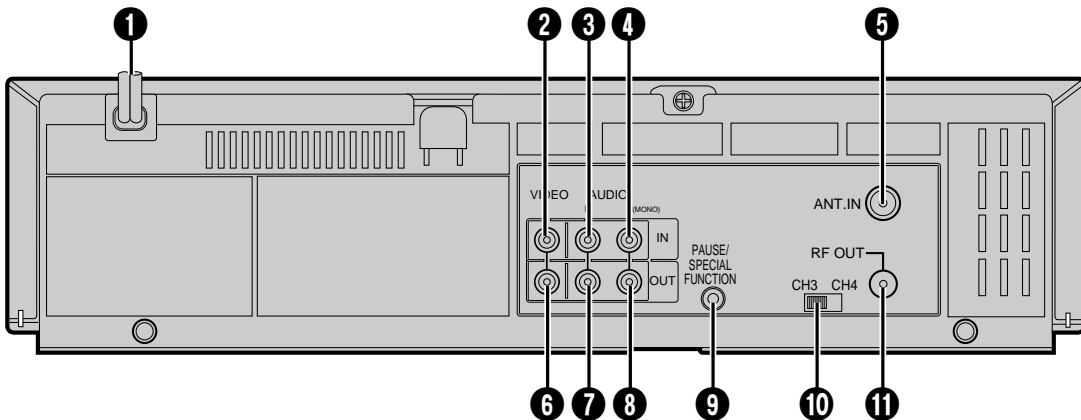

- 1 Power Cord (☞ pg. 4)
- 2 Video Input Connector (☞ pg. 32)
- 3 Audio Input Connector [R] (☞ pg. 32)
- 4 Mono Audio Input Connector (☞ pg. 32)
Audio Input Connector [L] (☞ pg. 32)
- 5 ANT. IN Connector (☞ pg. 4)
- 6 Video Output Connector (☞ pg. 4)
- 7 Hi-Fi Audio Output Connector [R] (☞ pg. 4)
- 8 Hi-Fi Audio Output Connector [L] (☞ pg. 4)
- 9 PAUSE/SPECIAL FUNCTION Connector
 - Remote PAUSE Connector (☞ pg. 30)
 - AV COMPU LINK Connector (☞ pg. 18)
 - Random Assemble Editing connector (☞ pg. 33)
- 10 Channel 3/4 Switch (☞ pg. 4)
- 11 RF OUT Connector (☞ pg. 4)

FRONT DISPLAY PANEL

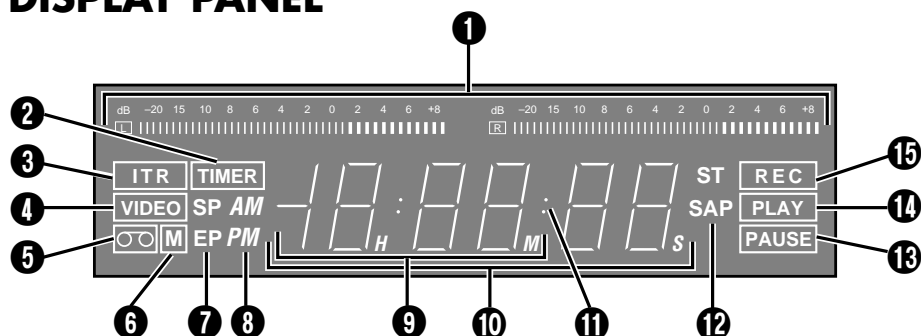

- 1 Audio Level Meter
- 2 Timer Mode Indicator (☞ pg. 26)
- 3 Instant Timer Recording Indicator (☞ pg. 25)
- 4 Video Mode Indicator (☞ pg. 5)
- 5 "Cassette Loaded" Mark
- 6 Counter Memory Mark (☞ pg. 17)
- 7 Tape Speed Indicators (☞ pg. 11)
- 8 AM/PM Indicators (☞ pg. 6)
- 9 Clock Display (☞ pg. 6)
- 10 Channel Display ["AU" for AUX mode] (☞ pg. 30)
- 11 Counter Display (☞ pg. 17)
- 12 Multichannel TV Sound Indicators (☞ pg. 24)
- 13 Pause Mode Indicator (☞ pg. 11)
- 14 Play Mode Indicator (☞ pg. 10)
- 15 Recording Mode Indicator (☞ pg. 11)

REMOTE CONTROL (Provided)

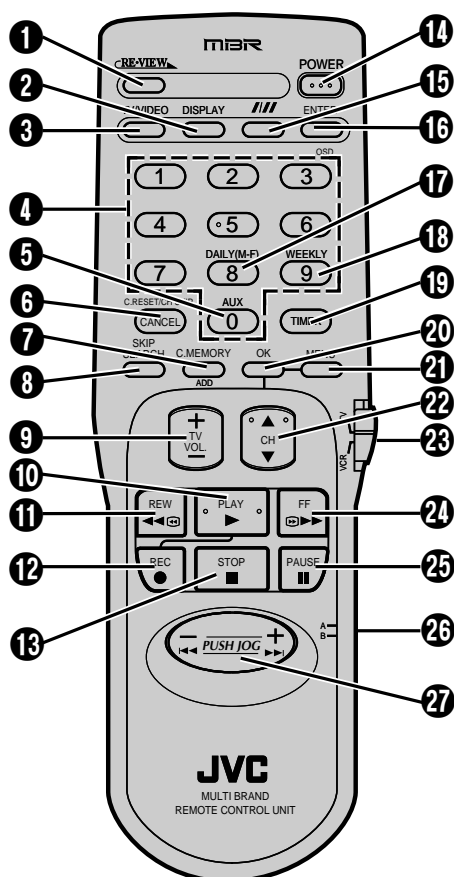

- 1 Instant REVIEW Button (☞ pg. 17)
- 2 DISPLAY Button (☞ pg. 17)
- 3 TV/VIDEO Button (☞ pg. 5)
- 4 NUMBER Buttons (☞ pg. 6)
- 5 "AUX" Mode Select Button (☞ pg. 30)
- 6 CANCEL Button (☞ pg. 27)
- 7 Counter [C.] RESET (☞ pg. 17)
- 8 SKIP SEARCH Button (☞ pg. 16)
- 9 Volume [VOL] +/- Buttons (☞ pg. 35)
- 10 PLAY Button (☞ pg. 10)
- 11 Rewind [REW] Button (☞ pg. 10)
- 12 Record [REC] Button (☞ pg. 11)
- 13 STOP Button (☞ pg. 10)
- 14 POWER ON/OFF Button (☞ pg. 5)
- 15 Recording Speed [SP/EP] Button (☞ pg. 11)
- 16 ENTER Button (☞ pg. 11)
- 17 On-Screen Display [OSD] Button (☞ pg. 15)
- 18 DAILY Timer Recording Button (☞ pg. 26)
- 19 WEEKLY Timer Recording Button (☞ pg. 26)
- 20 TIMER Button (☞ pg. 26)
- 21 OK Button (☞ pg. 5)
- 22 MENU Button (☞ pg. 5)
- 23 Channel [CH] ▲▼ Buttons (☞ pg. 5)
- 24 TV/VCR Switch (☞ pg. 35)
- 25 Fast-Forward [FF] Button (☞ pg. 10)
- 26 PAUSE Button (☞ pg. 11)
- 27 A/B Code Select Switch (☞ pg. 32)
- 27 PUSH JOG Button (☞ pg. 12)

GENERAL

Power requirement	: AC 110 – 220 V \sim , 50/60 Hz
Power consumption	: 21 W
Temperature	
Operating	: 5°C to 40°C (41°F to 104°F)
Storage	: –20°C to 60°C (–4°F to 140°F)
Operating position	: Horizontal only
Dimensions (W x H x D)	: 400 x 94 x 291 mm (15-3/4" x 3-3/4" x 11-1/2")
Weight	: 3.7 kg (8.2 lbs)
Format	: VHS NTSC standard
Maximum recording time	
SP	: 210 min. with ST-210 video cassette
EP	: 630 min. with ST-210 video cassette

VIDEO/AUDIO

Signal system	: NTSC-type color signal and EIA monochrome signal, 525 lines/60 fields
Recording/ Playback system	: DA-4 (Double Azimuth) head helical scan system
Signal-to-noise ratio	: 45 dB
Horizontal resolution	: 240 lines
Frequency range	
Normal audio	: 70 Hz to 10,000 Hz
Hi-Fi audio	: 20 Hz to 20,000 Hz
Input/Output	: RCA connectors (IN x 2, OUT x 1)

TUNER

Tuning system	: Frequency-synthesized tuner
Channel coverage	
VHF	: Channels 2–13
UHF	: Channels 14–69
CATV	: 113 Channels
RF output	: Channel 3 or 4 (switchable; preset to Channel 3 when shipped) 75 ohms, unbalanced

TIMER

Clock reference	: Quartz
Program capacity	: 1-year programmable timer/ 8 programs
Memory backup time	: Approx. 18 hours

ACCESSORIES

Provided accessories	: RF cable, Infrared remote control unit, "AAA" battery x 2, Conversion plug
----------------------	---

Specifications shown are for SP mode unless otherwise specified. E. & O.E. Design and specifications subject to change without notice.